

**Montageanleitung / Gebrauchsanleitung**  
**Mounting instructions / Instructions for use**  
**Instructions de montage / Mode d'emploi**  
**Instrucciones de montaje / Modo de empleo**



# Inhaltsverzeichnis

## Directory

### Montage

### Mounting

Tischgestell, Table frame .....	-3-
Anbauprofil kurz (Basis), Mounting profile, short (base) .....	-10-
Anbauprofil lang (durchgängig), Mounting profile long (continuous) .....	-10-
Anbauprofil kurz (Aufbau), Mounting profile, short (top).....	-13-
Ablageböden, Shelves .....	-14-
Anschlagkante, Stop edge .....	-18-
Anschlagbügel, Stop bracket .....	-18-
Fachteiler offen, Shelf dividers open .....	-19-
Schublade, Drawer .....	-20-
Tischplatte, Table top .....	-21-
Tragplatte für Waage, Supporting plate .....	-24-
Tischplatte mit Waagenausschnitt, Table top with scale cutout .....	-25-
Lochrückwand, Perforated back panel .....	-29-
Mini PC - Halter, Thin-client holder .....	-29-
Utensilo komplett, Utensils rack, complete .....	-30-
Ablageboden mit Utensilo, Shelf with utensils rack .....	-32-
Ablageboden mit Tastaturauszug Shelves with retracting keyboard tray .....	-34-
Halter für Klebebandabroller, Holder for adhesive tape dispenser .....	-35-
Getränkhalter für Flaschen, Beverage holder .....	-35-
Kabelwanne, Cable tray .....	-36-
Anbau- Schneidvorrichtung, Add-on cutter .....	-38-
Rollenhalter, Roll holder .....	-39-
Spaltabdeckung für Ablageböden, Cover rail .....	-42-
Kabelkanal, Cable duct .....	-43-
Kleinteilefach, Drawer with extension .....	-44-
4-fach Steckdose, 4-socket outlet .....	-44-
Köcher für Stifte, Kabelbinder etc., Holder for pens's, cable straps, etc. ....	-45-
Adapter für TFT-Gelenkarme, Adapter for TFT folding arms ...	-46-
Tastatur- und Mausablage, Keyboard and mouse platform with folding arm .....	-47-
Trennblech für Blechablage, Partition plate for shelves .....	-48-
Trennbügel für Kartonagen, Separating brackets for cartons under the table .....	-48-
Halter für Waagenanzeigergerät, Holder for scale display unit .....	-49-
Universalablage, Universal shelf .....	-50-
Achssatz kpl. (zwischen den Holmen), Spindle set complete (between the uprights) .....	-51-
Lagerschalen zwischen den Anbauprofilen, Bearing shell between the mounting profile ....	-52-
Gebrauchsinformation, Information for use .....	-54-

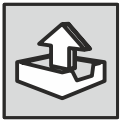

Lieferumfang  
Contents  
Contenu  
Contenido



Montageanleitung  
Mounting instructions  
Instructions de montage  
Instrucciones de montaje



Gebrauchsanleitung  
Instructions for use  
Mode d'emploi  
Modo de empleo



73100600, 73100601,  
73100700, 73100701,  
73100800, 73100801

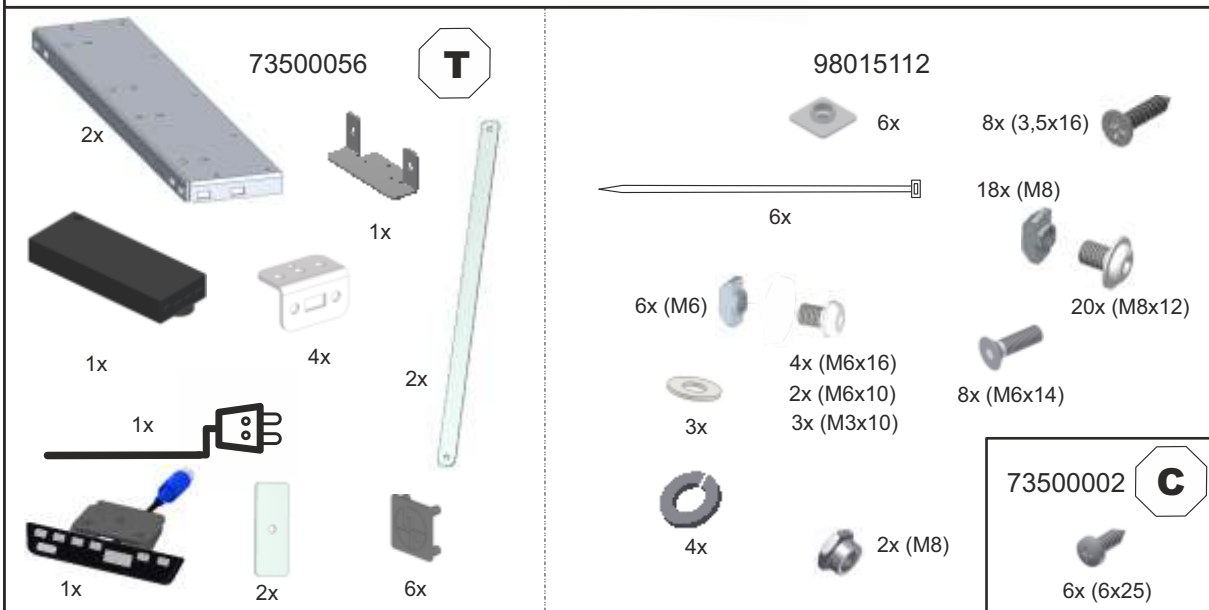
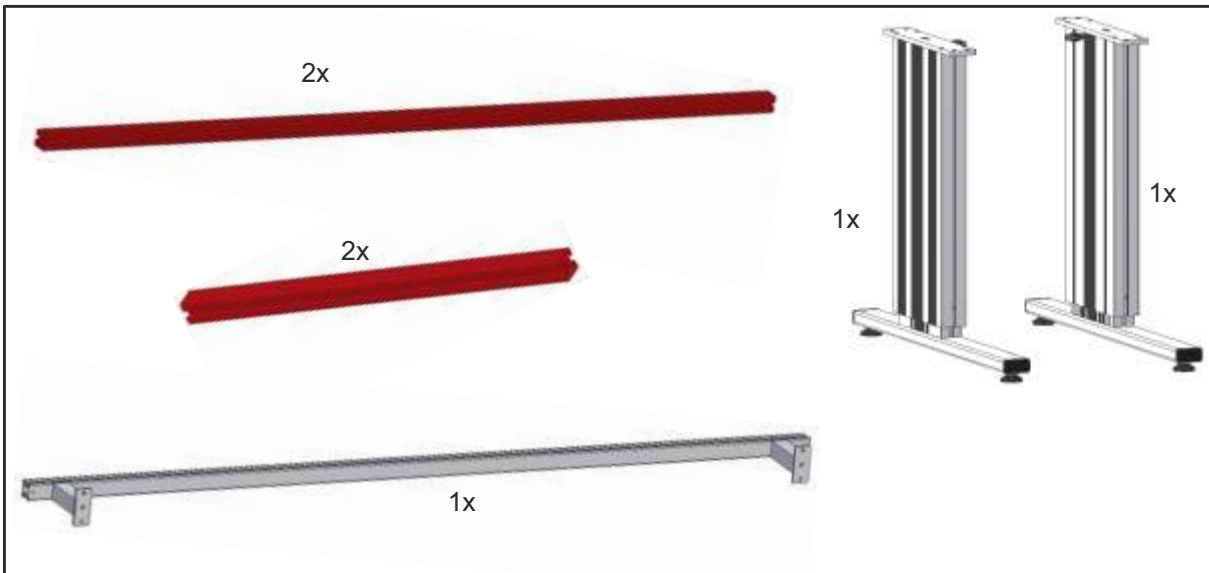

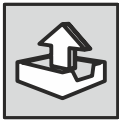

Lieferumfang  
Contents  
Contenu  
Contenido



Montageanleitung  
Mounting instructions  
Instructions de montage  
Instrucciones de montaje



Gebrauchsanleitung  
Instructions for use  
Mode d'emploi  
Modo de empleo



T

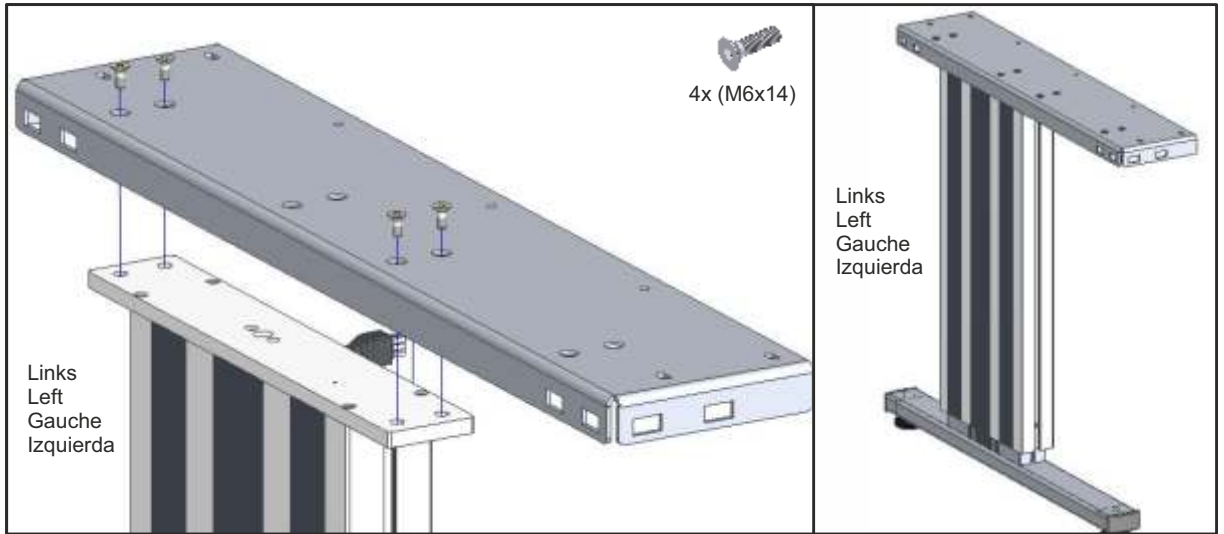

T

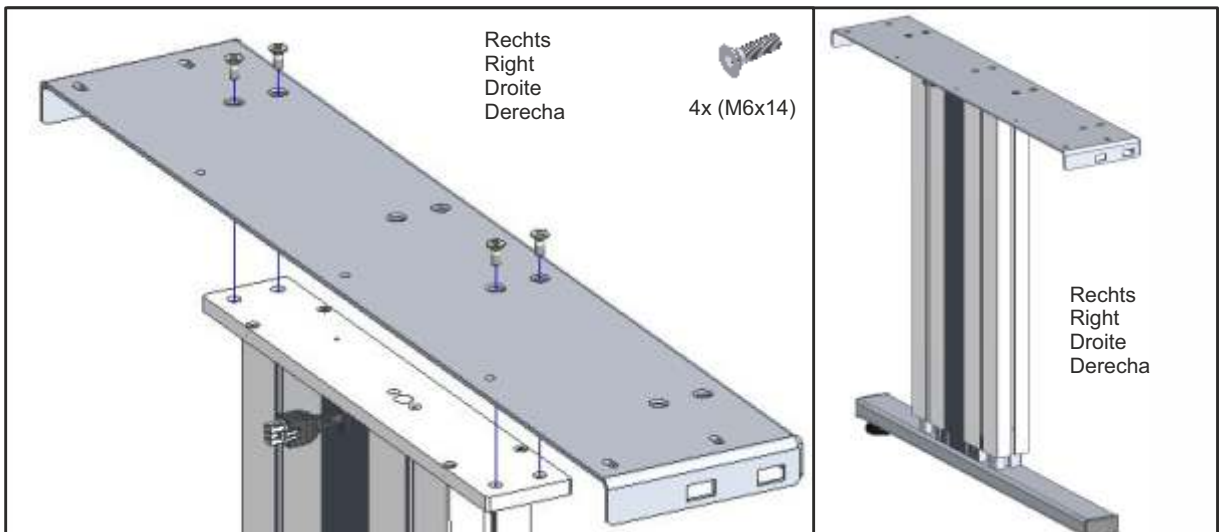

T

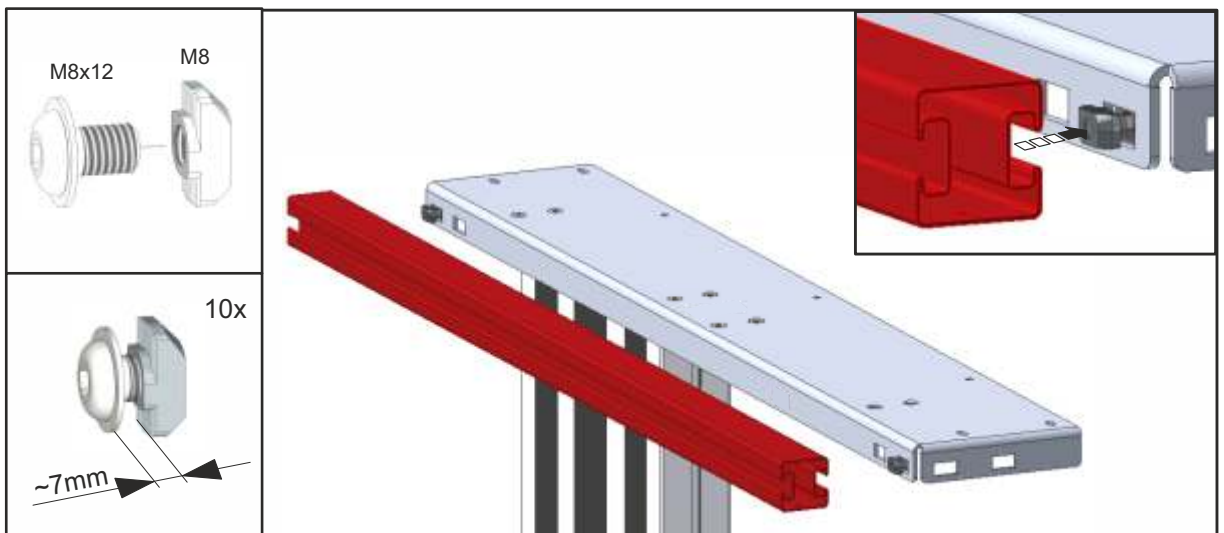

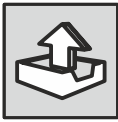

Lieferumfang  
Contents  
Contenu  
Contenido



Montageanleitung  
Mounting instructions  
Instructions de montage  
Instrucciones de montaje



Gebrauchsanleitung  
Instructions for use  
Mode d'emploi  
Modo de empleo

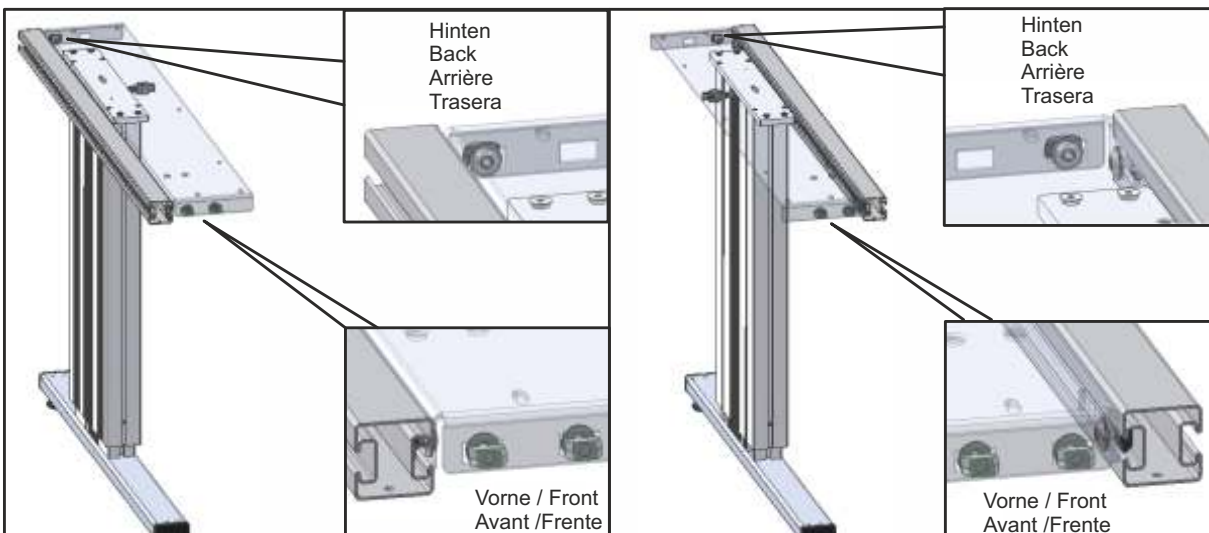
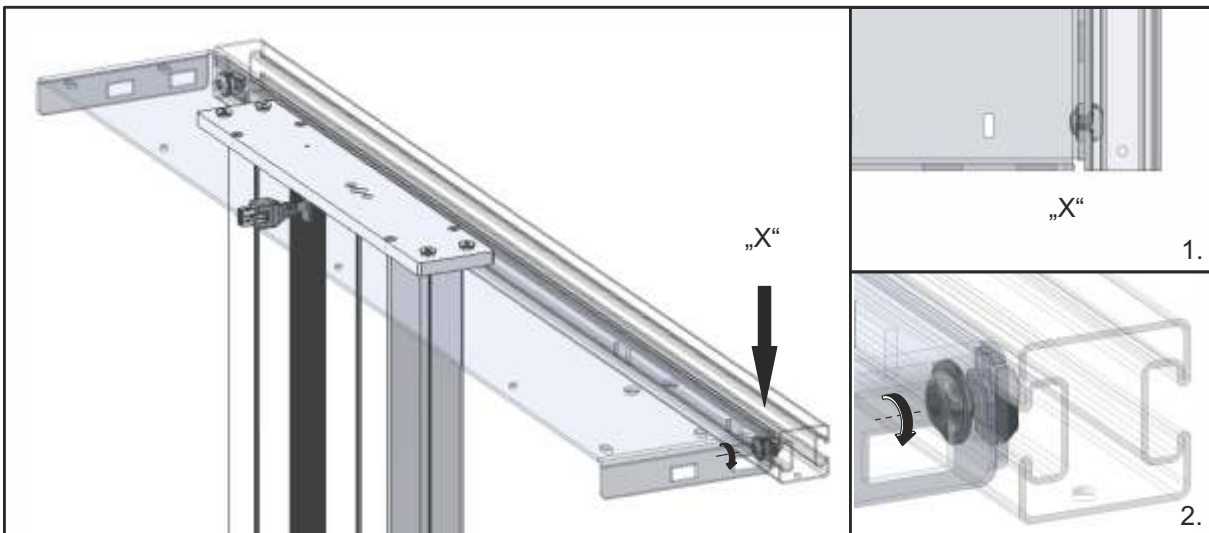
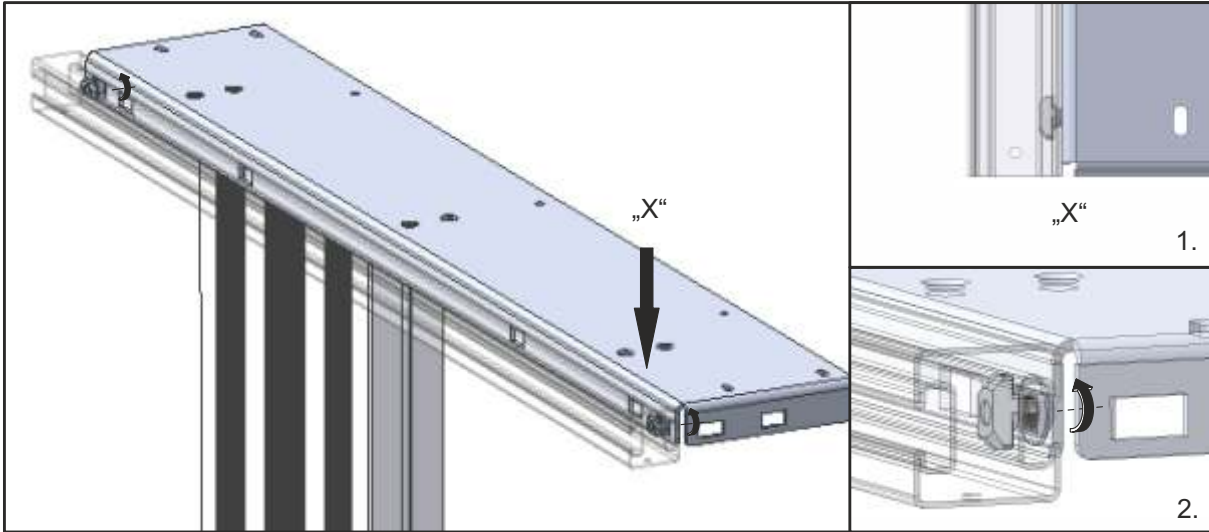





Montageanleitung  
 Mounting instructions  
 Instructions de montage  
 Instrucciones de montaje



Gebrauchsanleitung  
 Instructions for use  
 Mode d'emploi  
 Modo de empleo



2 Personen  
 2 Persons  
 2 Personnes  
 2 Personas

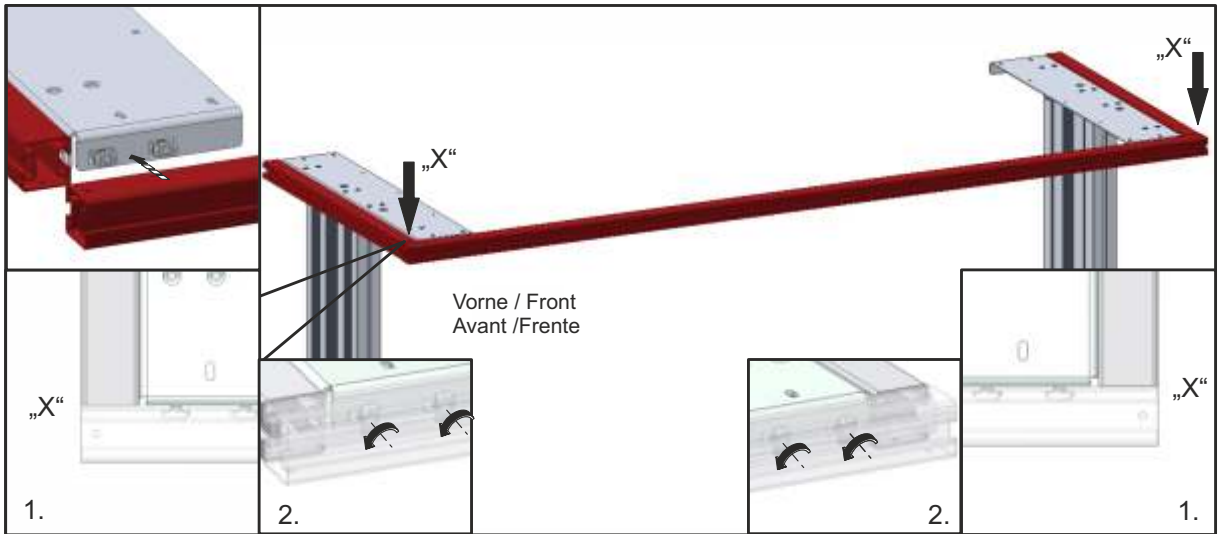



Montageanleitung  
 Mounting instructions  
 Instructions de montage  
 Instrucciones de montaje



Gebrauchsanleitung  
 Instructions for use  
 Mode d'emploi  
 Modo de empleo



2 Personen  
 2 Persons  
 2 Personnes  
 2 Personas

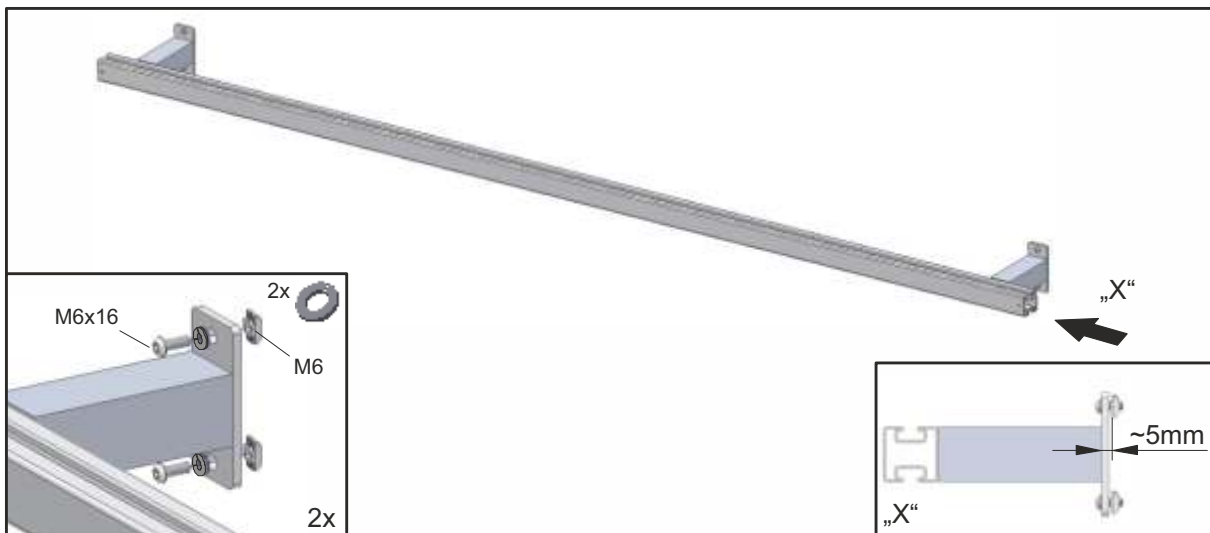
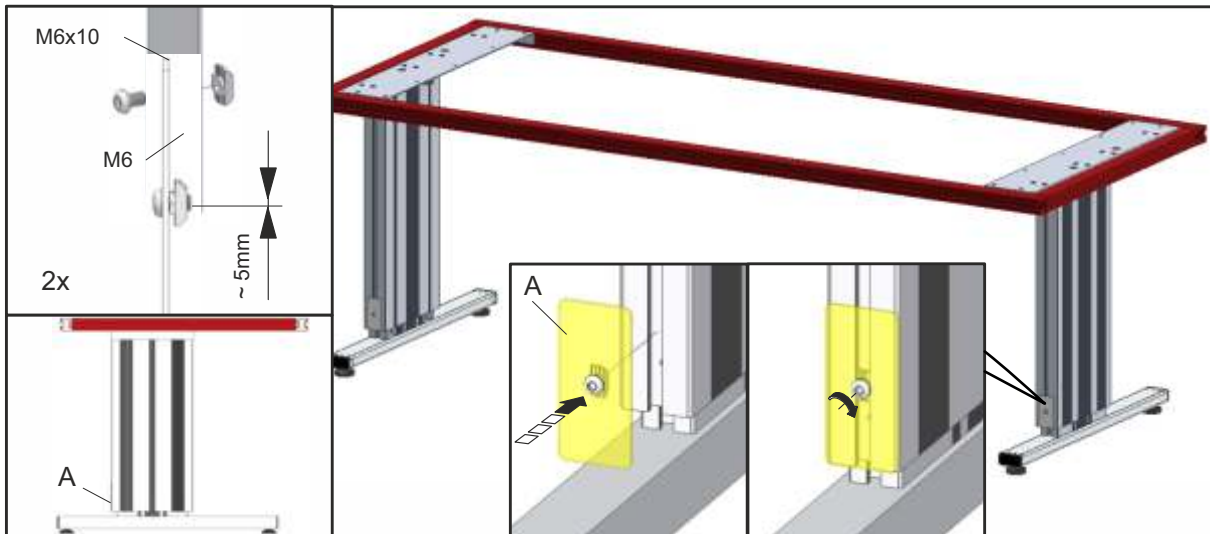

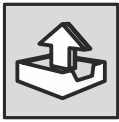

Lieferumfang  
Contents  
Contenu  
Contenido



Montageanleitung  
Mounting instructions  
Instructions de montage  
Instrucciones de montaje



Gebrauchsanleitung  
Instructions for use  
Mode d'emploi  
Modo de empleo



T



T

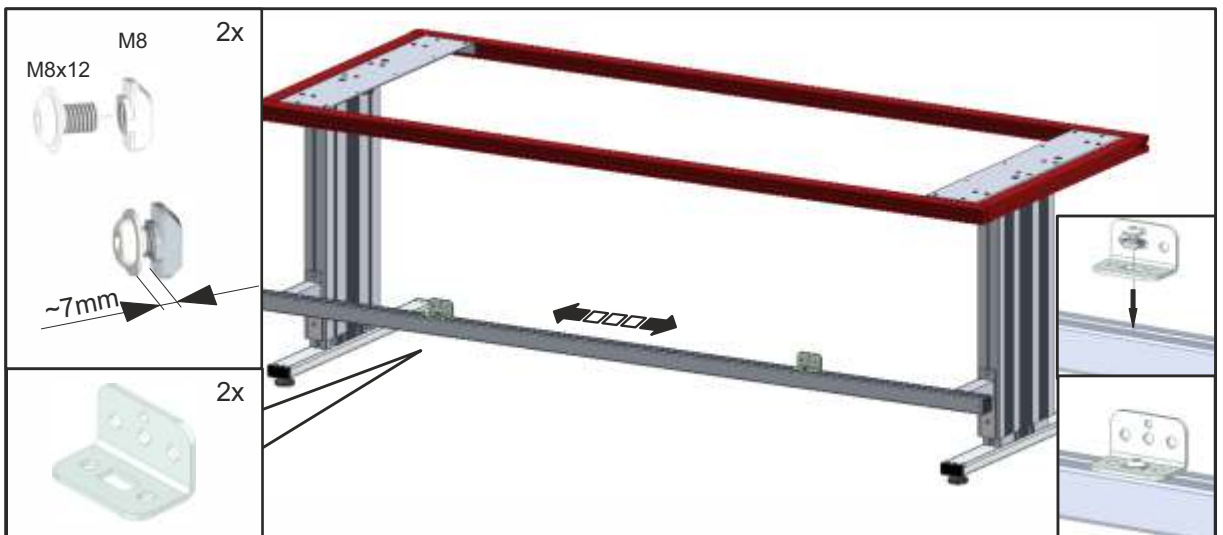

T

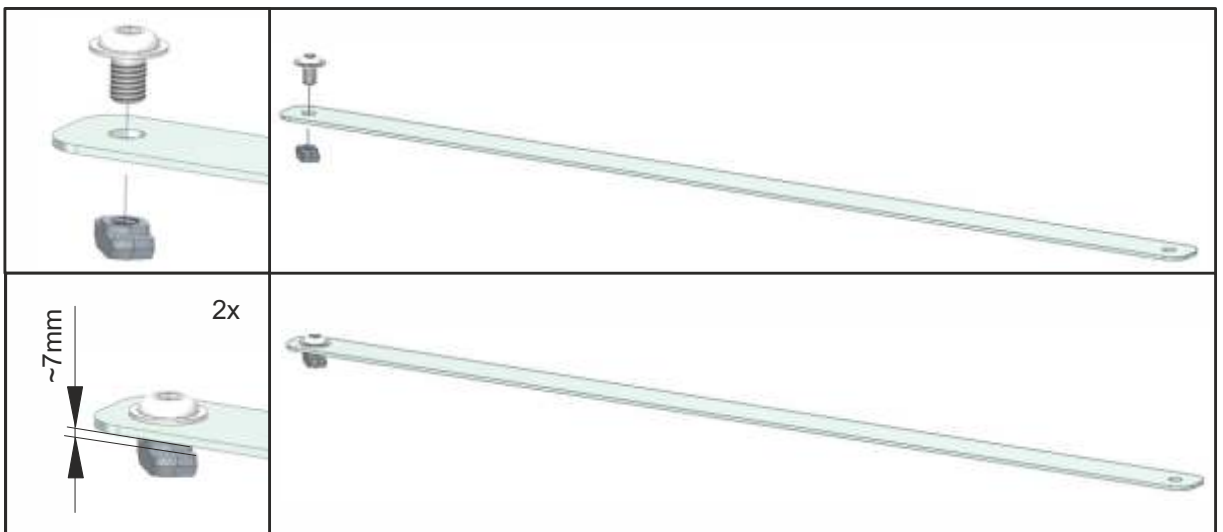





Lieferumfang  
Contents  
Contenu  
Contenido



Montageanleitung  
Mounting instructions  
Instructions de montage  
Instrucciones de montaje



Gebrauchsanleitung  
Instructions for use  
Mode d'emploi  
Modo de empleo

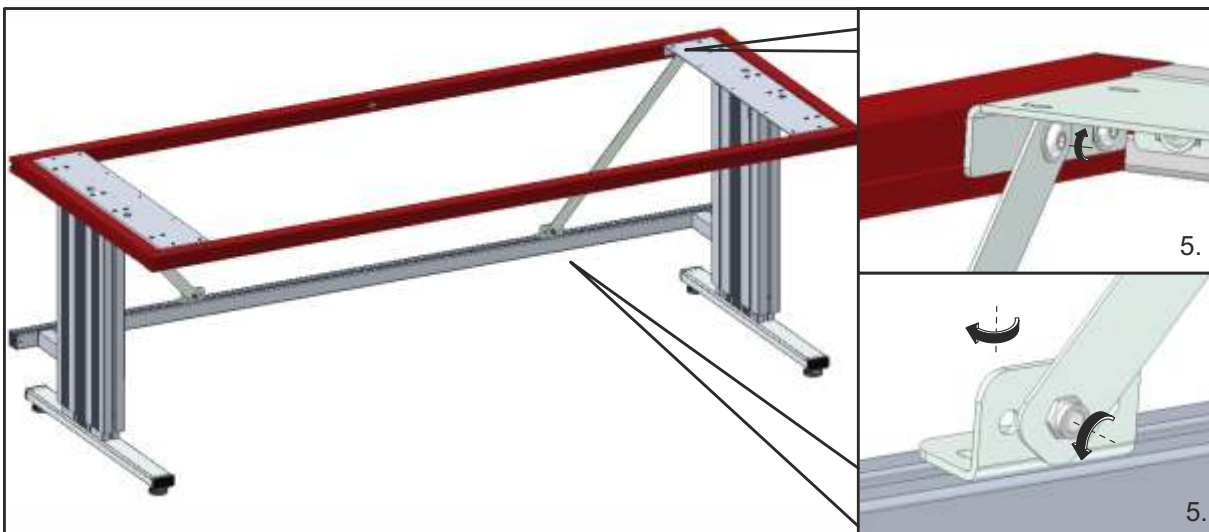
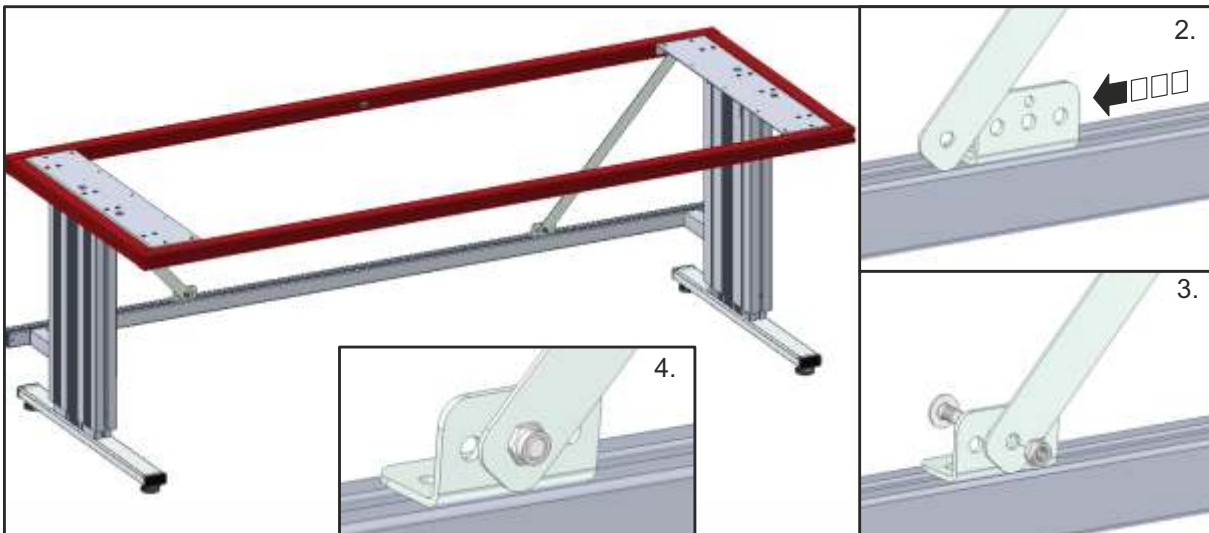



Lieferumfang  
Contents  
Contenu  
Contenido



Montageanleitung  
Mounting instructions  
Instructions de montage  
Instrucciones de montaje



Gebrauchsanleitung  
Instructions for use  
Mode d'emploi  
Modo de empleo



**T**



**T**

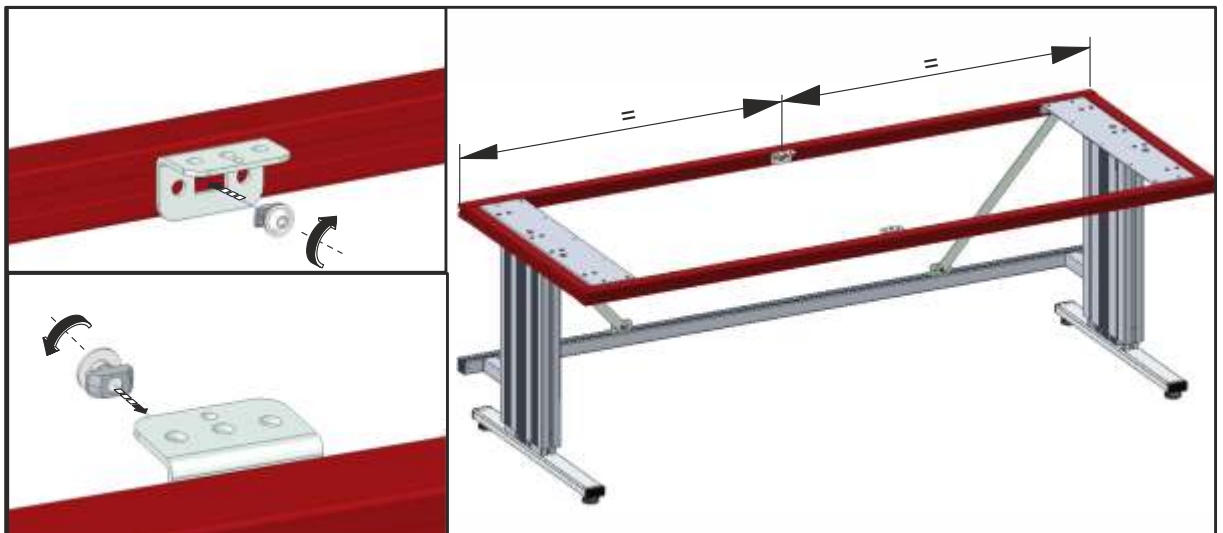

73309200, 73312400

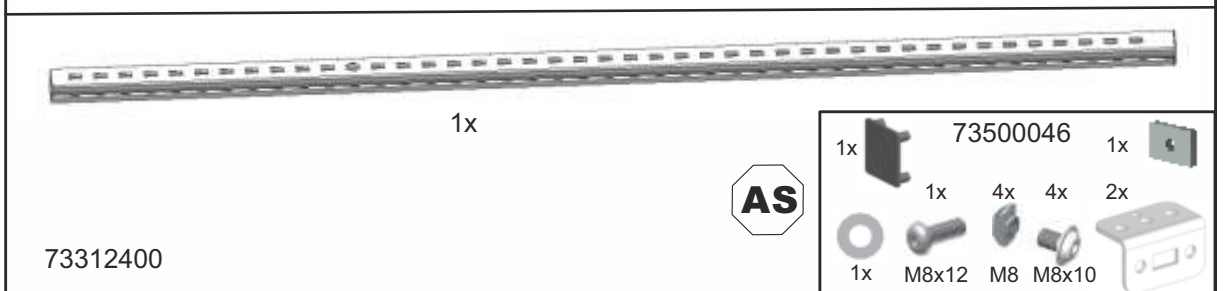
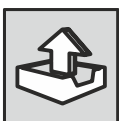
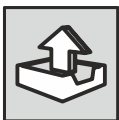

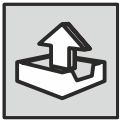

Lieferumfang  
Contents  
Contenu  
Contenido



Montageanleitung  
Mounting instructions  
Instructions de montage  
Instrucciones de montaje



Gebrauchsanleitung  
Instructions for use  
Mode d'emploi  
Modo de empleo

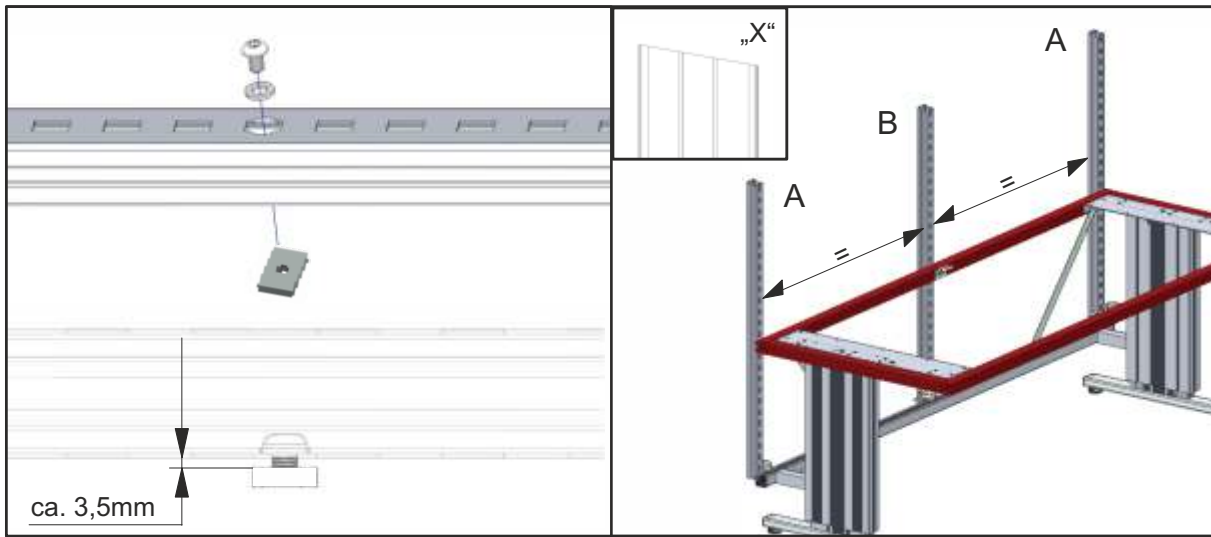

D

AS

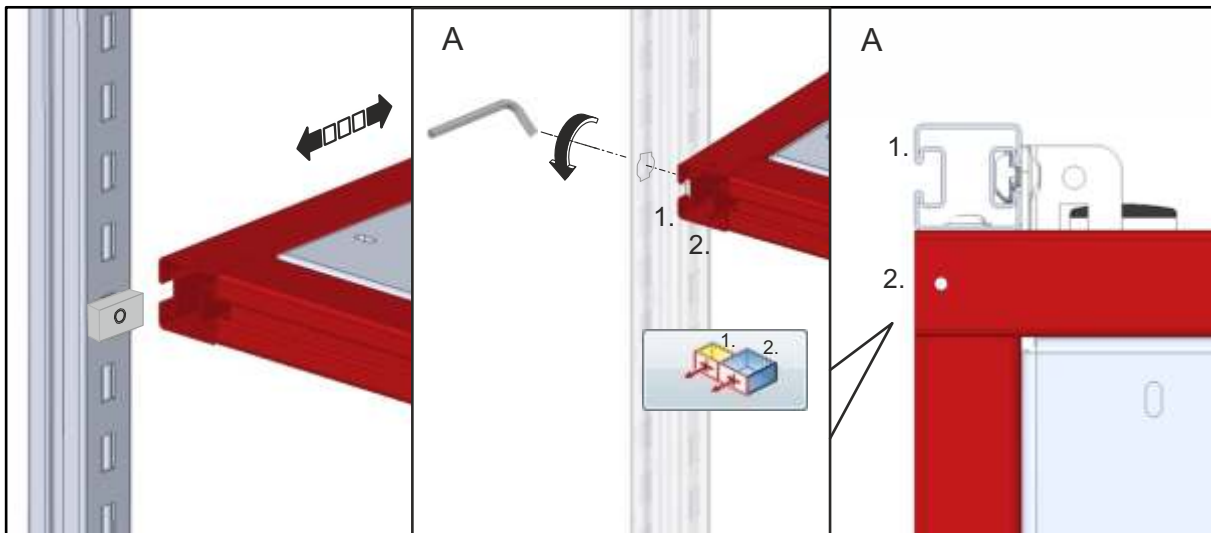

D

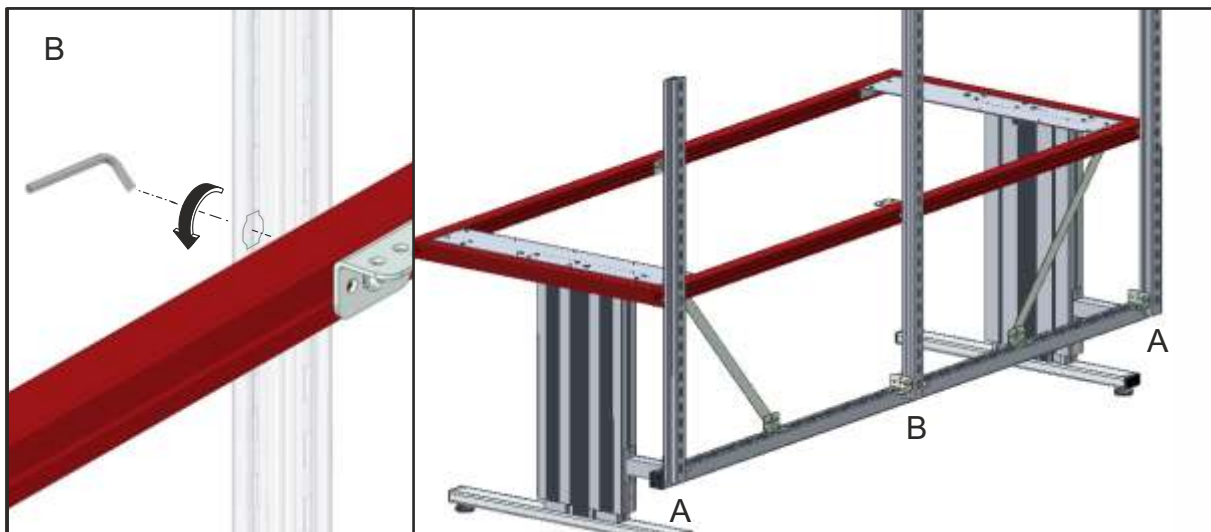

D

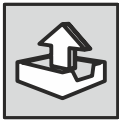

Lieferumfang  
Contents  
Contenu  
Contenido



Montageanleitung  
Mounting instructions  
Instructions de montage  
Instrucciones de montaje



Gebrauchsanleitung  
Instructions for use  
Mode d'emploi  
Modo de empleo



D

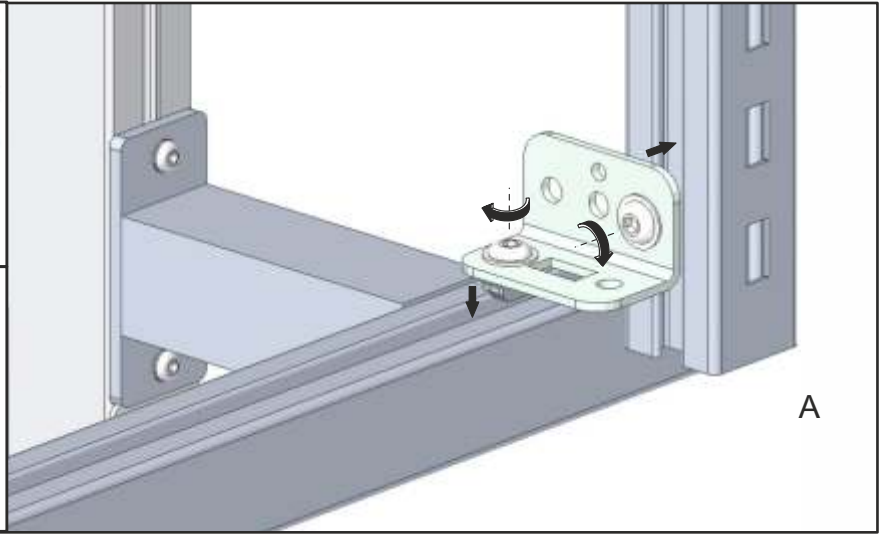
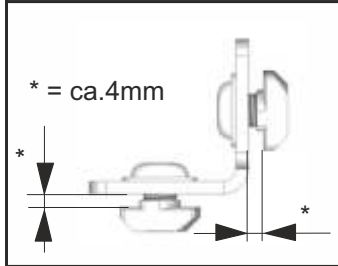
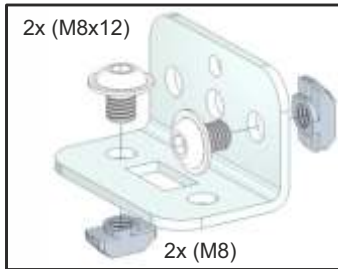

D

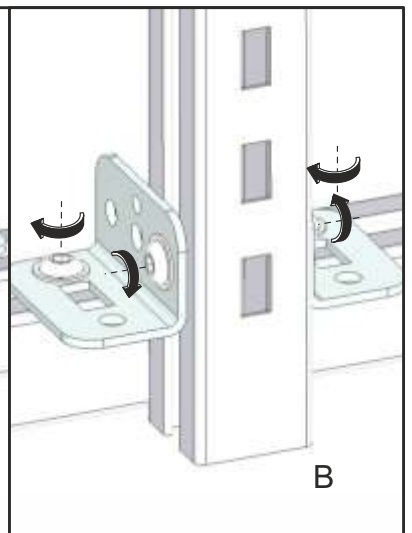
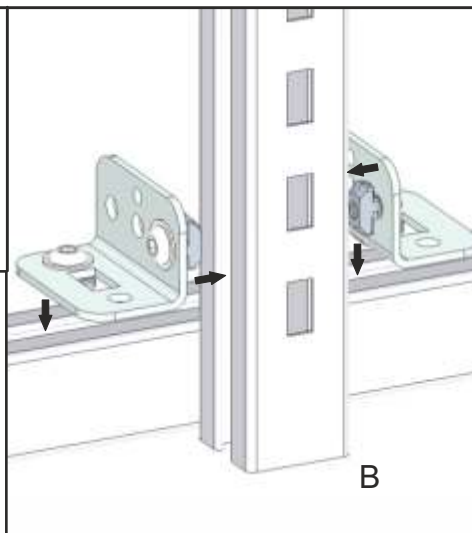
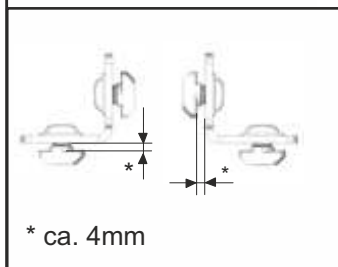

D

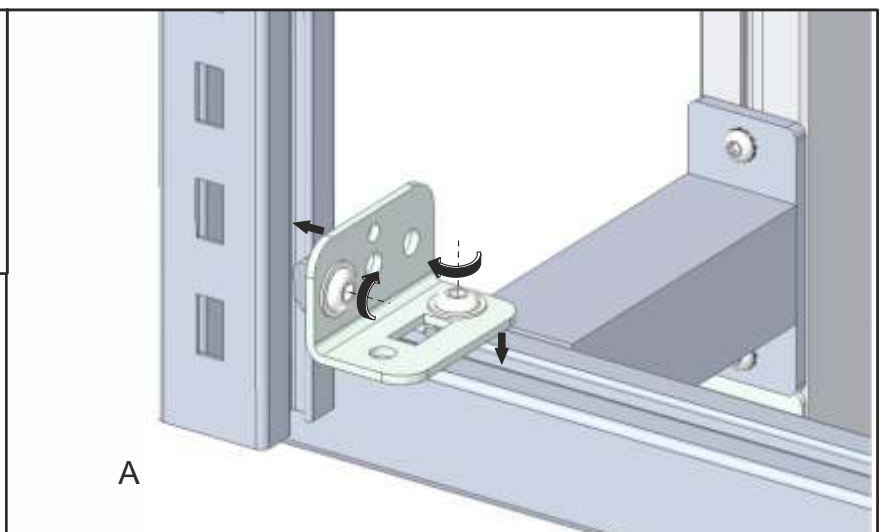
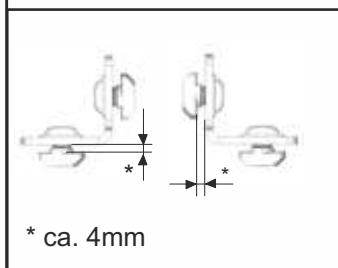
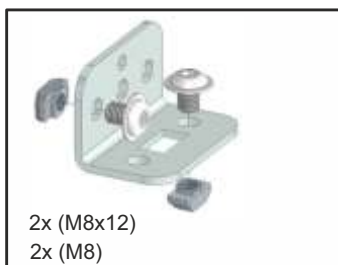



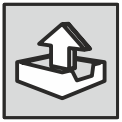

Lieferumfang  
Contents  
Contenu  
Contenido



Montageanleitung  
Mounting instructions  
Instructions de montage  
Instrucciones de montaje



Gebrauchsanleitung  
Instructions for use  
Mode d'emploi  
Modo de empleo

73309300

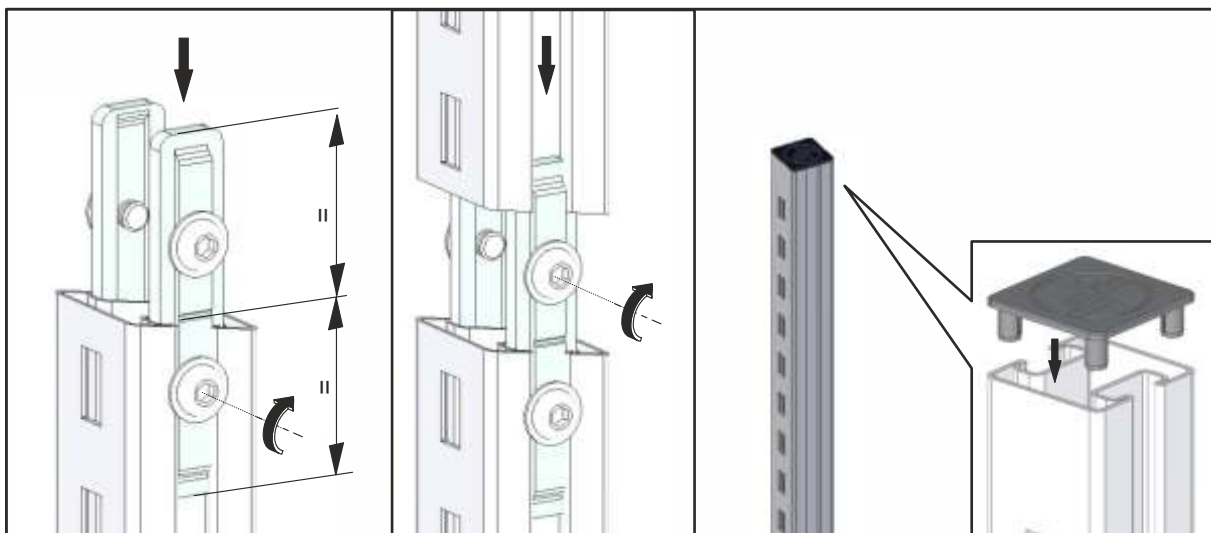
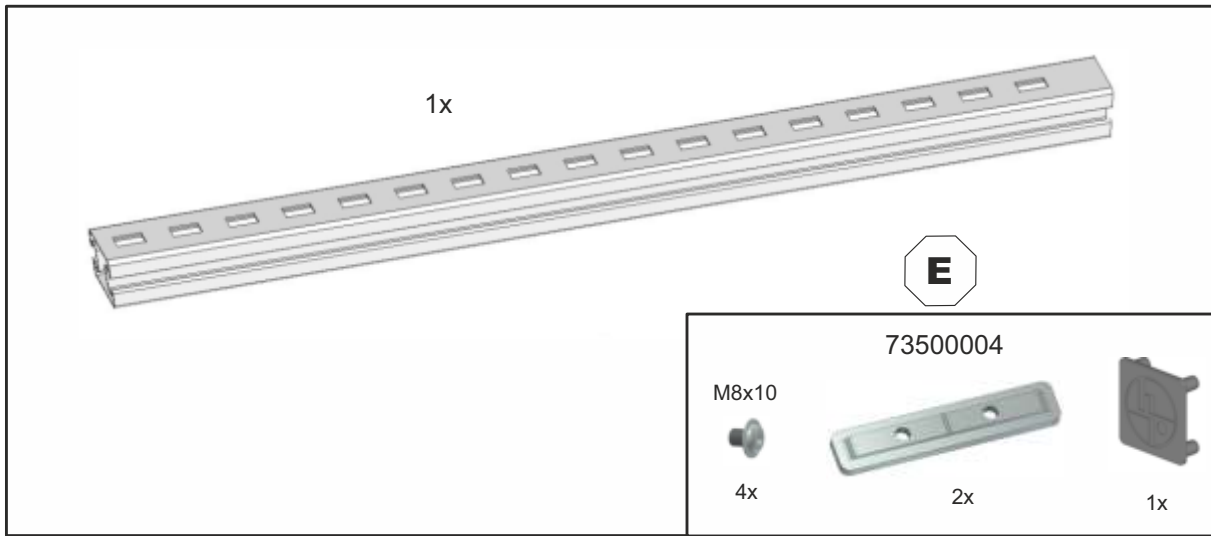
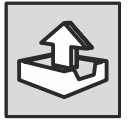



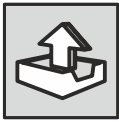

Lieferumfang  
Contents  
Contenu  
Contenido



Montageanleitung  
Mounting instructions  
Instructions de montage  
Instrucciones de montaje



Gebrauchsanleitung  
Instructions for use  
Mode d'emploi  
Modo de empleo

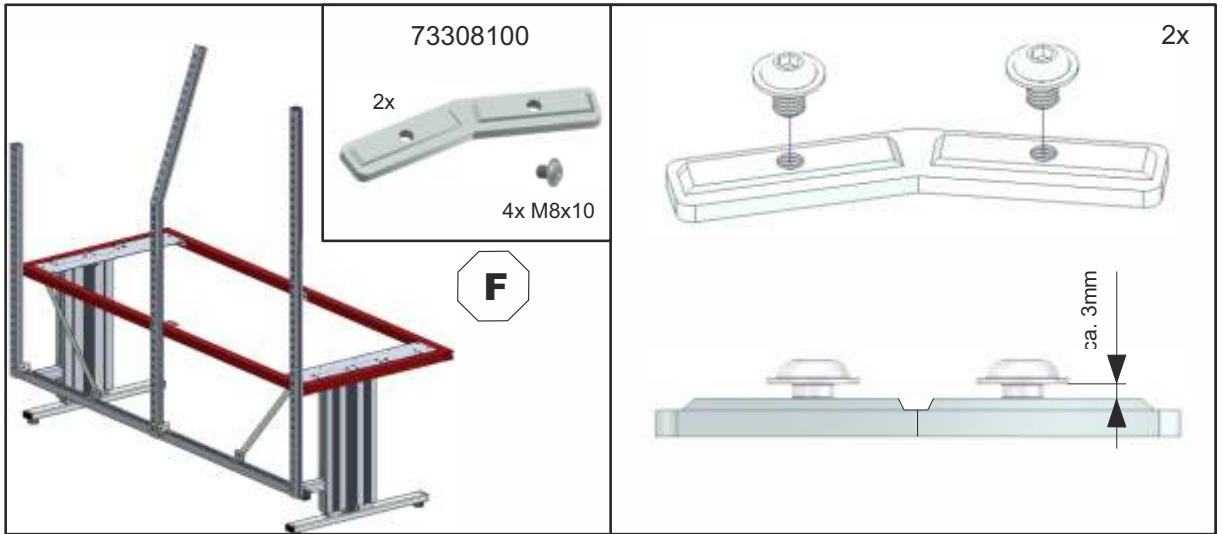

F

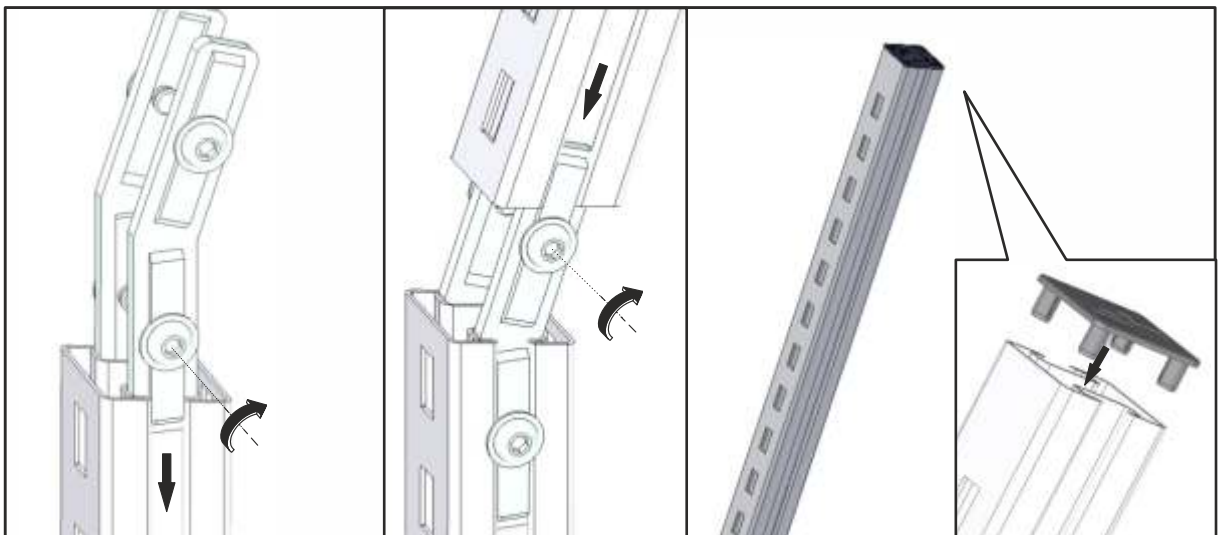

733069..., 733070..., 733072..., 733073..., 733075..., 733076..., 733130..

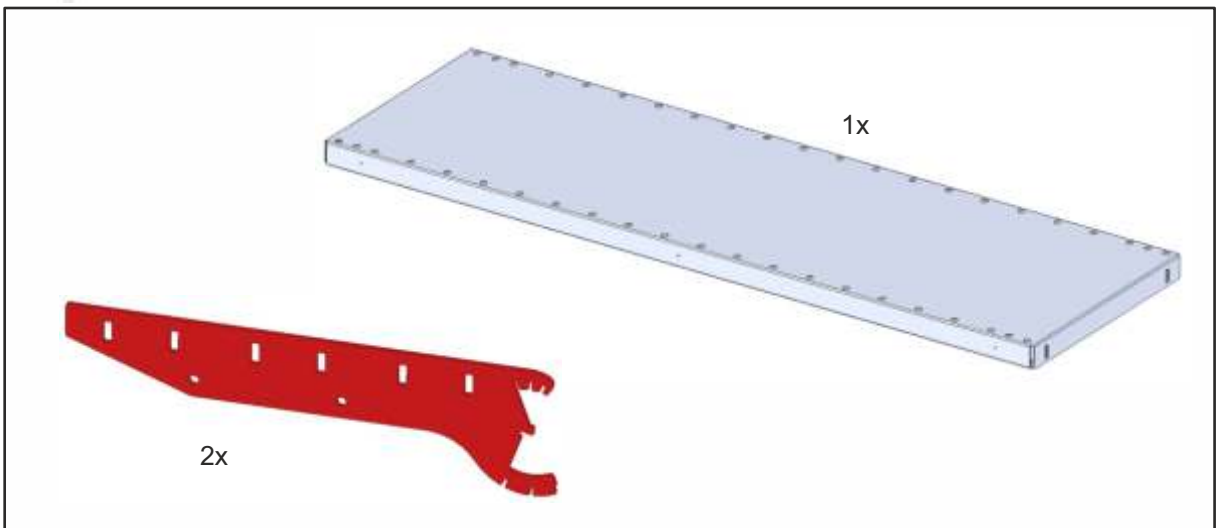
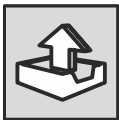

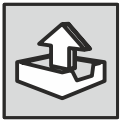

Lieferumfang  
Contents  
Contenu  
Contenido



Montageanleitung  
Mounting instructions  
Instructions de montage  
Instrucciones de montaje



Gebrauchsanleitung  
Instructions for use  
Mode d'emploi  
Modo de empleo

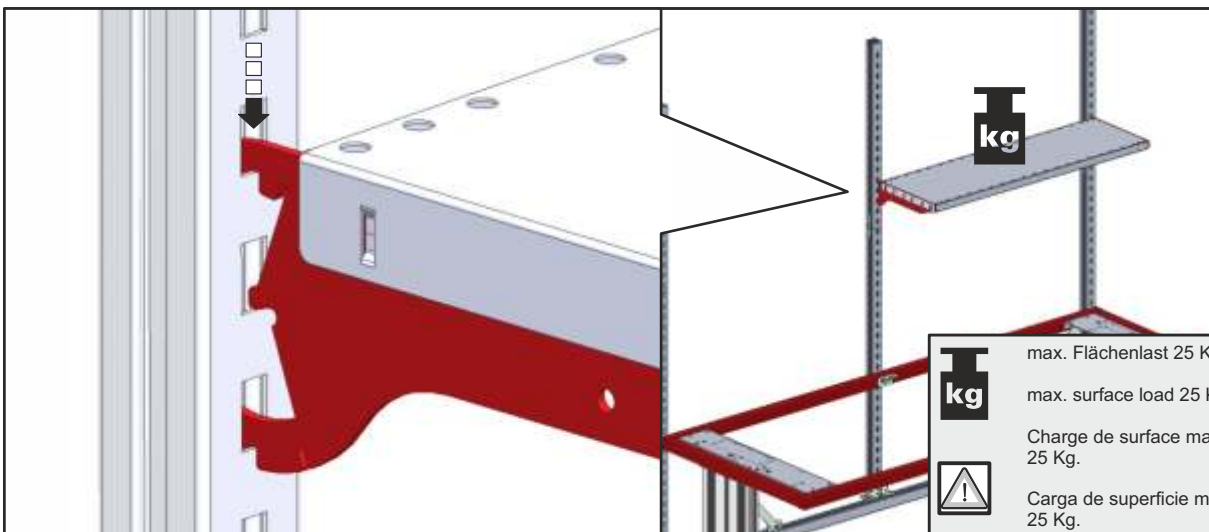
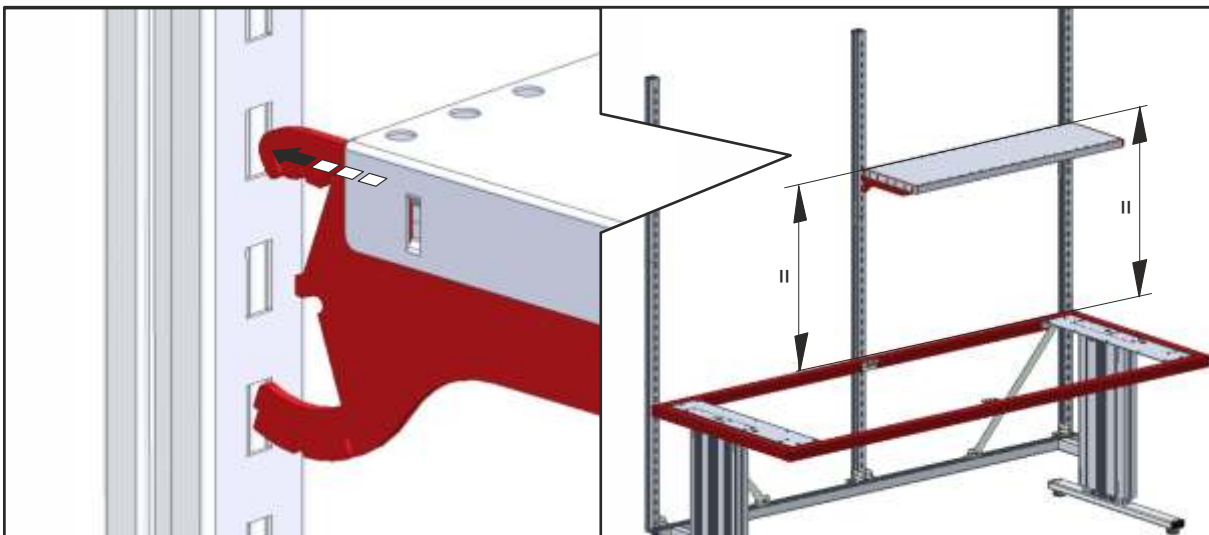
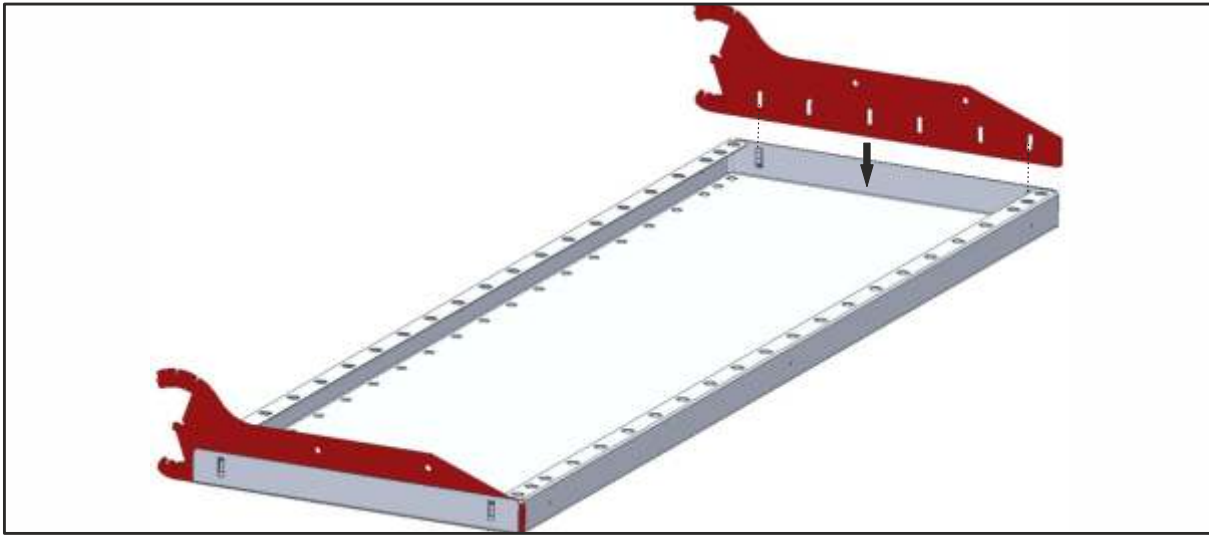

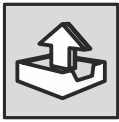

Lieferumfang  
Contents  
Contenu  
Contenido



Montageanleitung  
Mounting instructions  
Instructions de montage  
Instrucciones de montaje



Gebrauchsanleitung  
Instructions for use  
Mode d'emploi  
Modo de empleo



733071..., 733074..

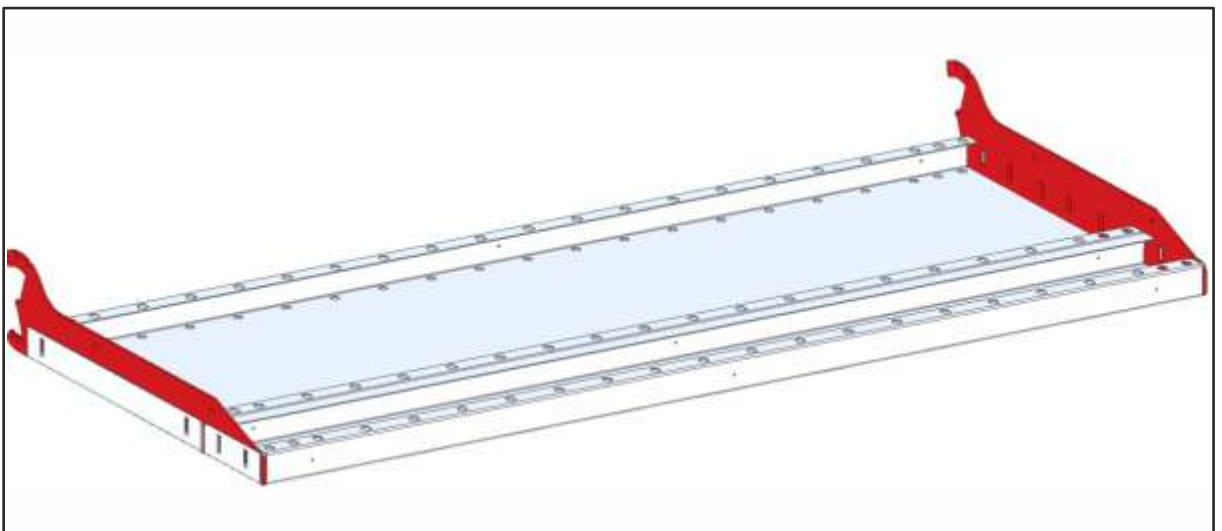
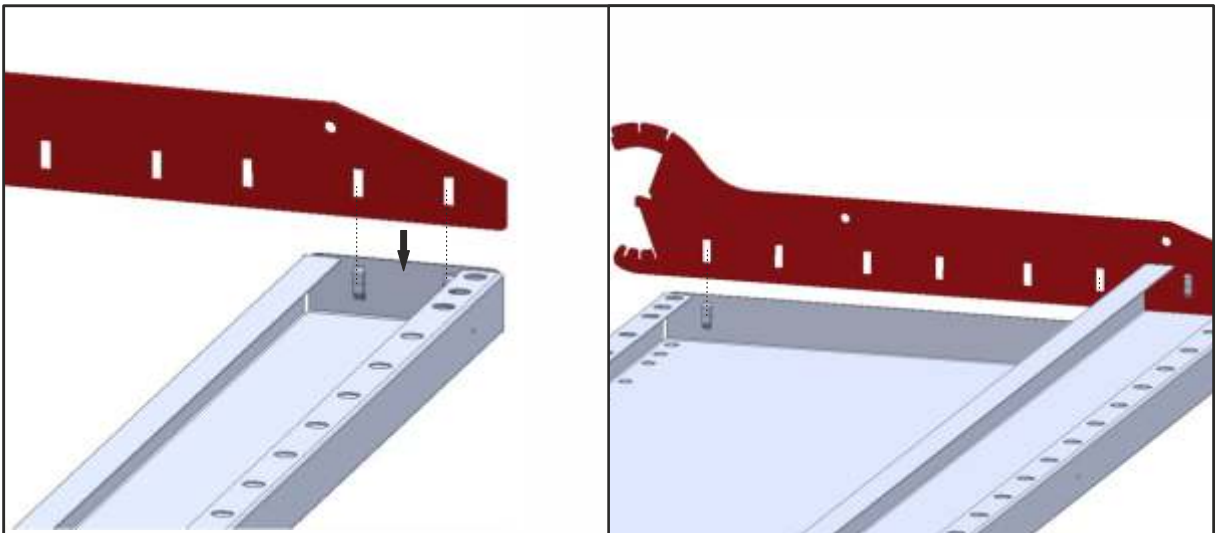
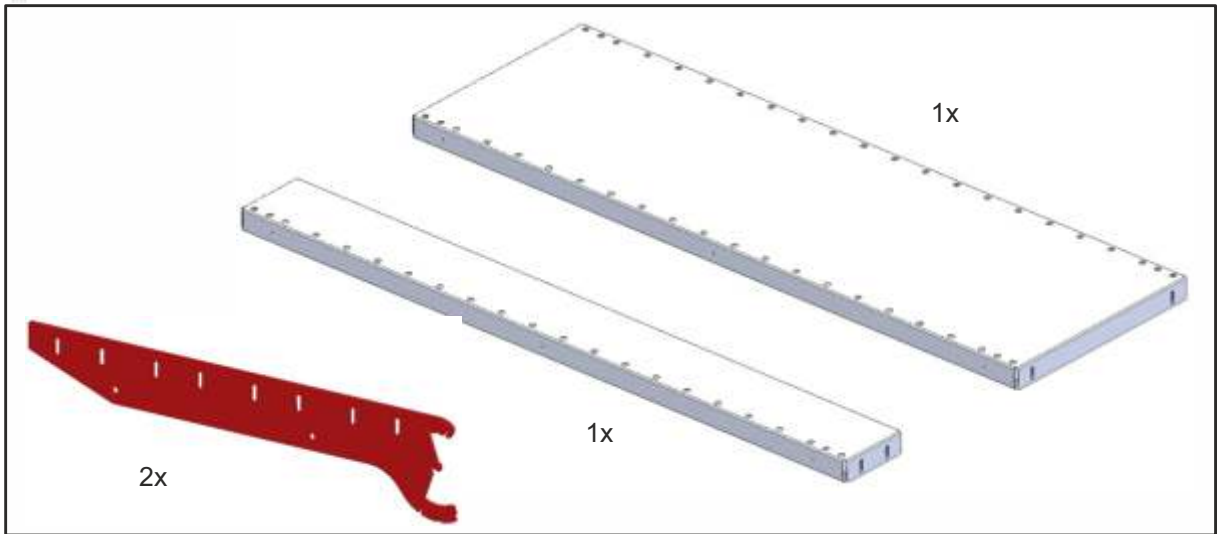
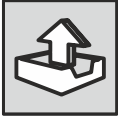

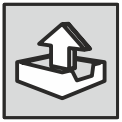

Lieferumfang  
Contents  
Contenu  
Contenido



Montageanleitung  
Mounting instructions  
Instructions de montage  
Instrucciones de montaje



Gebrauchsanleitung  
Instructions for use  
Mode d'emploi  
Modo de empleo

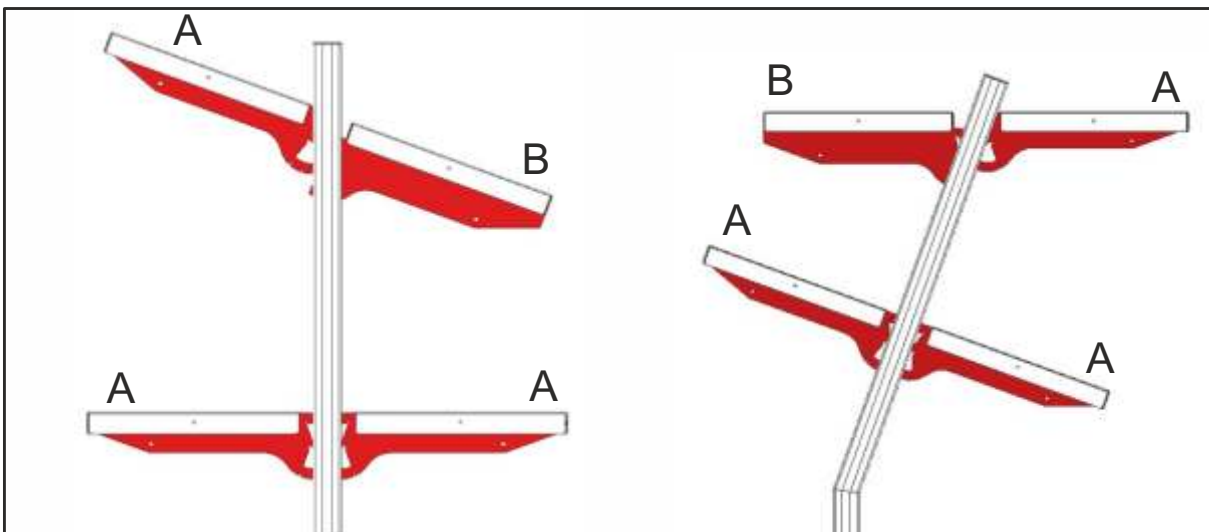
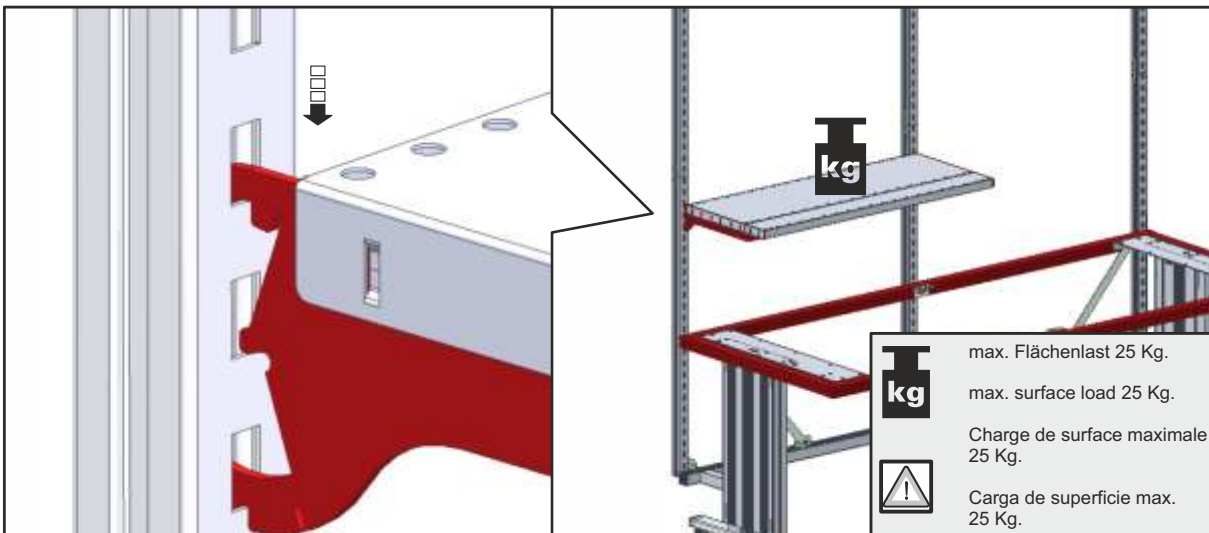
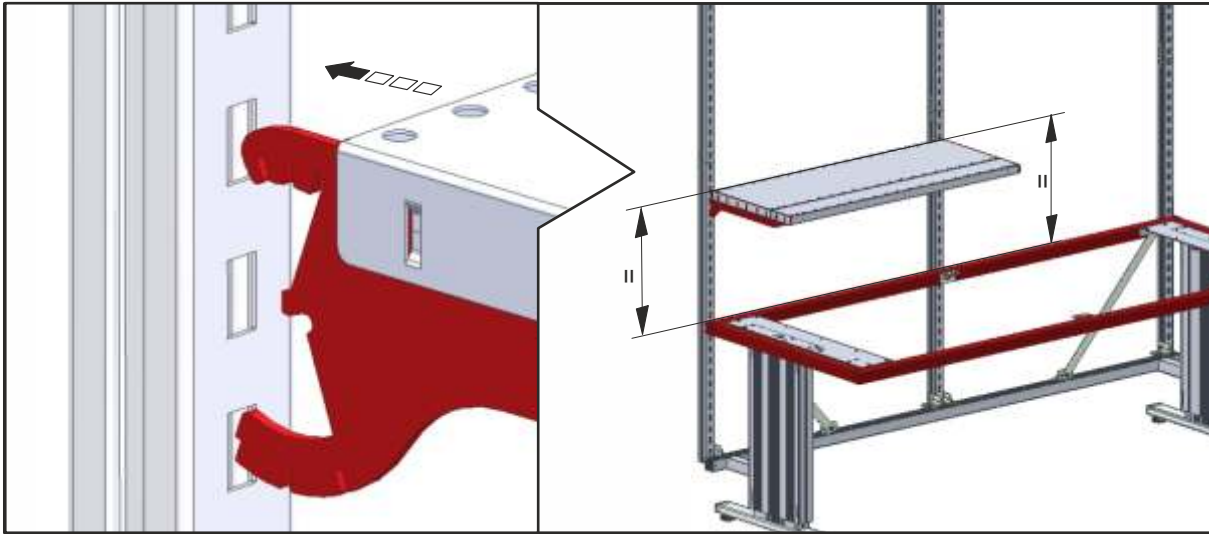

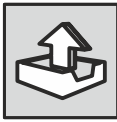

Lieferumfang  
Contents  
Contenu  
Contenido



Montageanleitung  
Mounting instructions  
Instructions de montage  
Instrucciones de montaje



Gebrauchsanleitung  
Instructions for use  
Mode d'emploi  
Modo de empleo



733020..., 733094..., 733141..

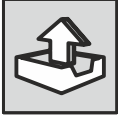

733020..., 733094..

1x



73500006

4,2x9,5



3x

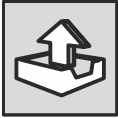

733141..

1x



73600163

4,2x9,5



5x

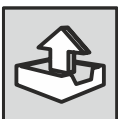
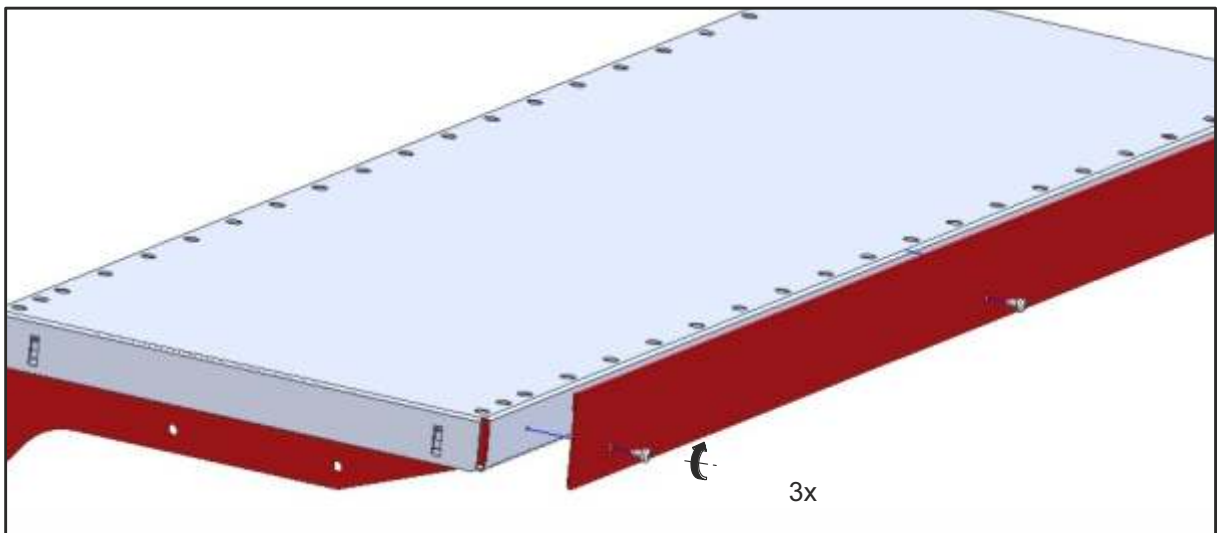

73301900

1x

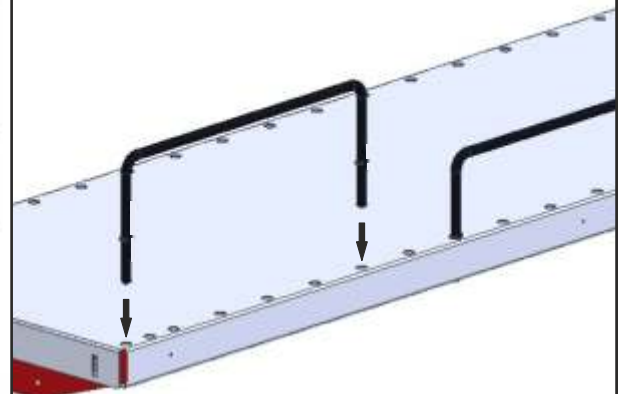
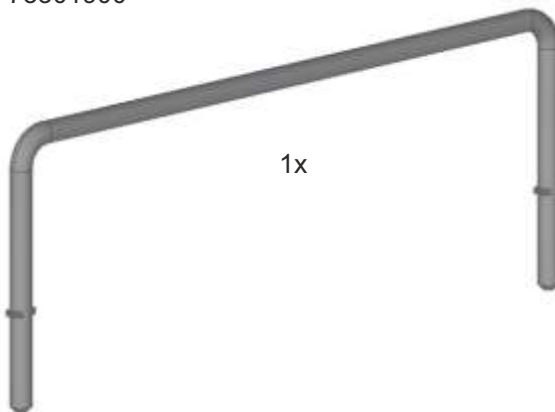



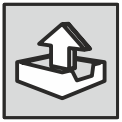

Lieferumfang  
Contents  
Contenu  
Contenido



Montageanleitung  
Mounting instructions  
Instructions de montage  
Instrucciones de montaje



Gebrauchsanleitung  
Instructions for use  
Mode d'emploi  
Modo de empleo

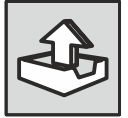
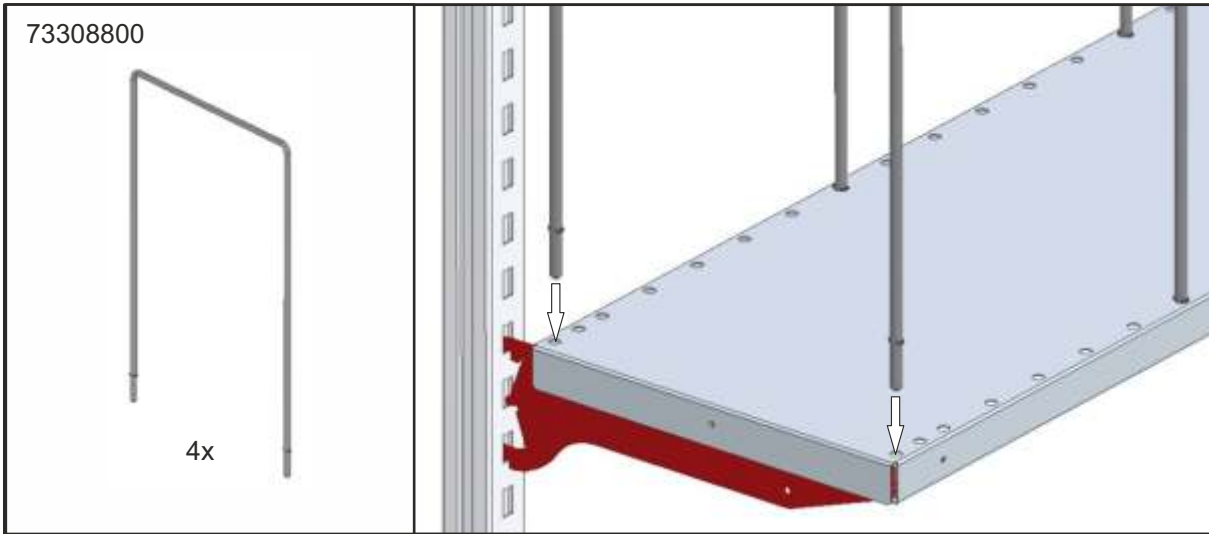

73314500, 73304501

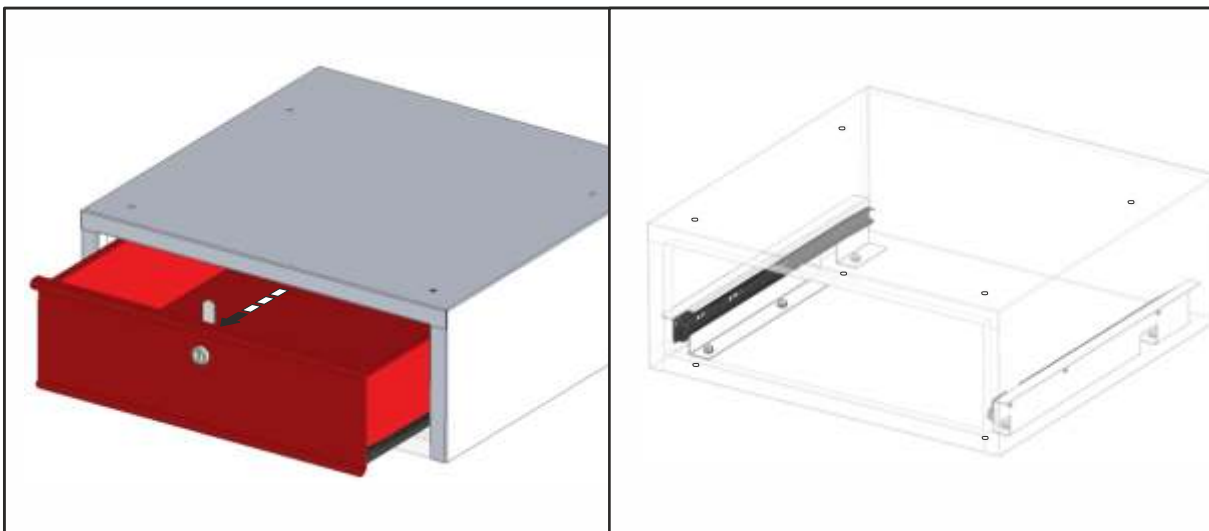
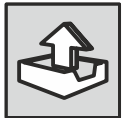
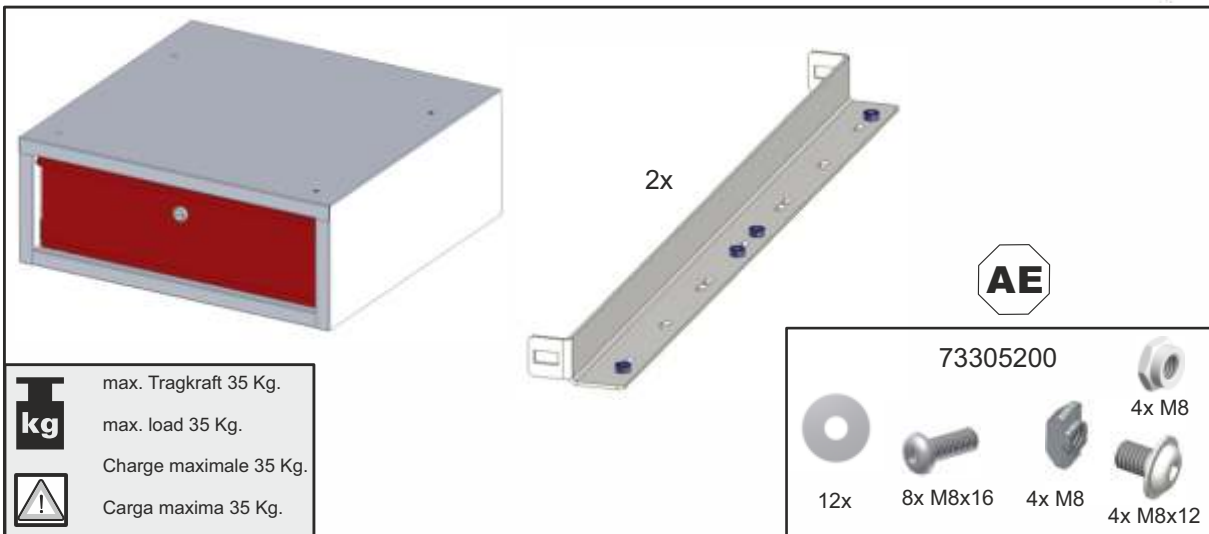

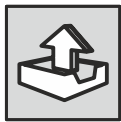

Lieferumfang  
Contents  
Contenu  
Contenido



Montageanleitung  
Mounting instructions  
Instructions de montage  
Instrucciones de montaje



Gebrauchsanleitung  
Instructions for use  
Mode d'emploi  
Modo de empleo



AE

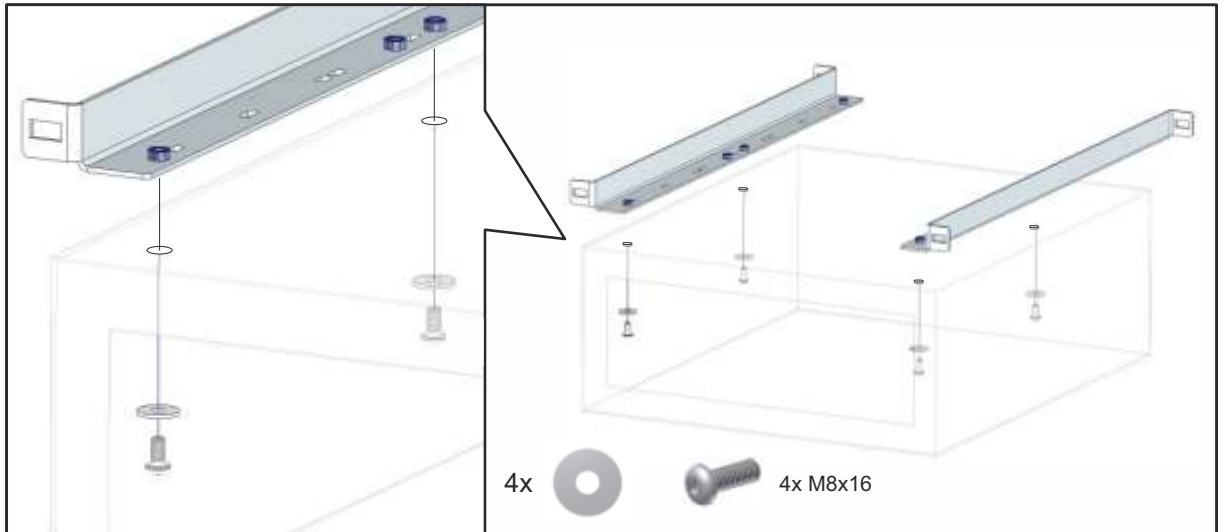

AE

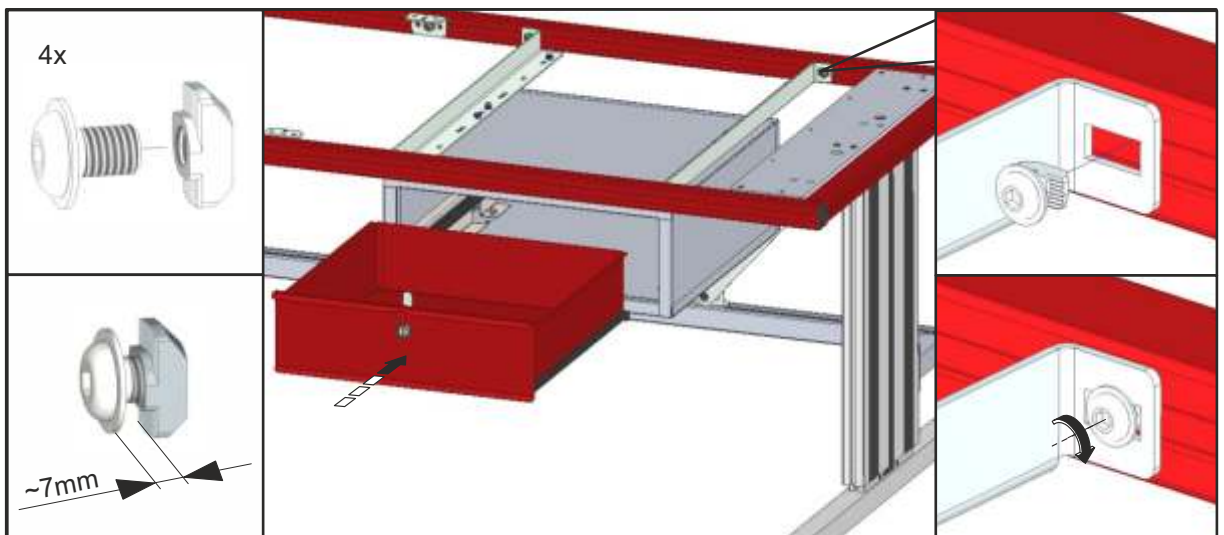

73314500 + 73314600



AE

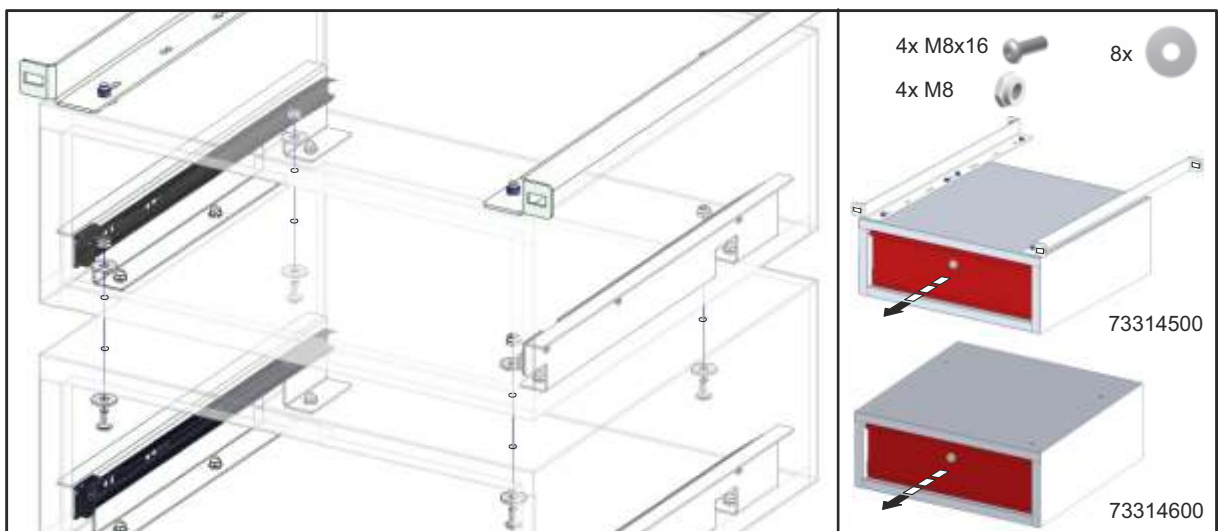



Montageanleitung  
 Mounting instructions  
 Instructions de montage  
 Instrucciones de montaje



Gebrauchsanleitung  
 Instructions for use  
 Mode d'emploi  
 Modo de empleo



2 Personen  
 2 Persons  
 2 Personnes  
 2 Personas

4x



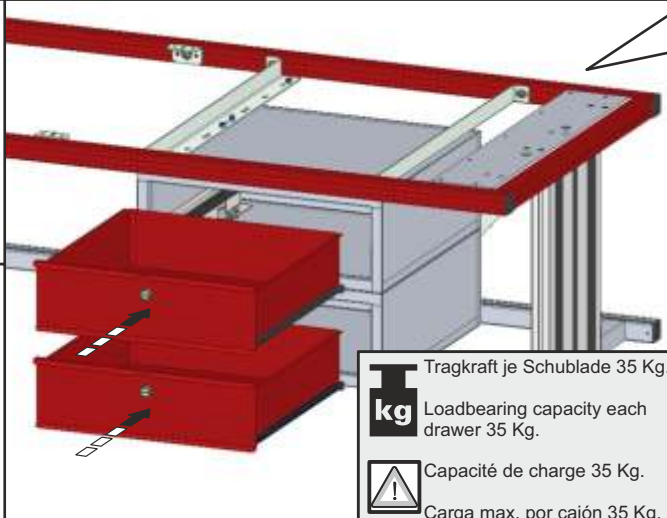

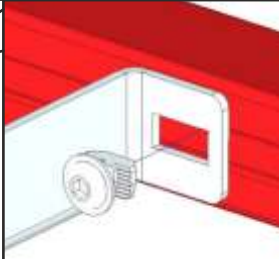

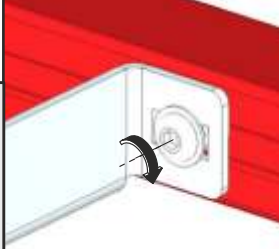

**kg** Tragkraft je Schublade 35 Kg.  
 Loadbearing capacity each drawer 35 Kg.

Capacité de charge 35 Kg.  
 Carga max. por cajón 35 Kg.

~7mm



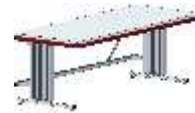

7320....

1x

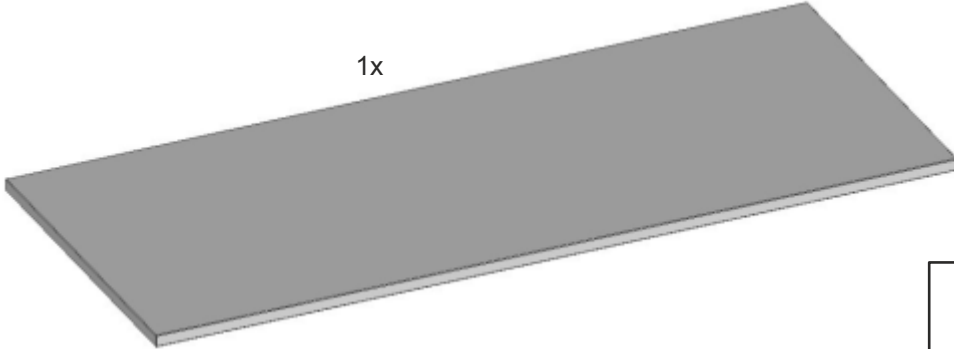

**C**

73500002

6x  6x25

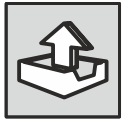









Montageanleitung  
 Mounting instructions  
 Instructions de montage  
 Instrucciones de montaje



Gebrauchsanleitung  
 Instructions for use  
 Mode d'emploi  
 Modo de empleo



2 Personen  
 2 Persons  
 2 Personnes  
 2 Personas



C

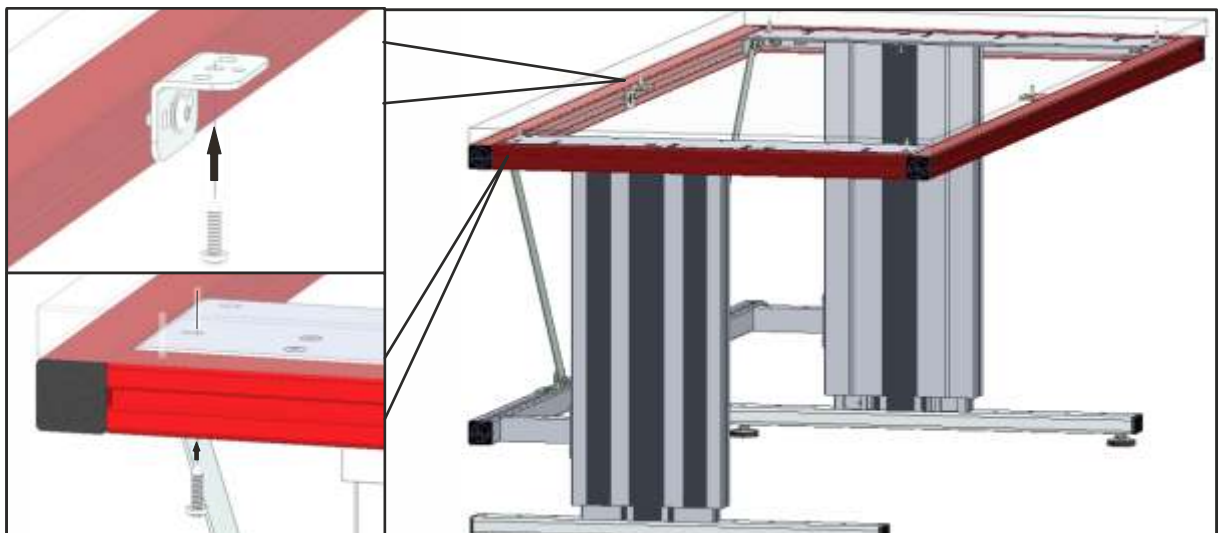

T







Montageanleitung  
Mounting instructions  
Instructions de montage  
Instrucciones de montaje



Gebrauchsanleitung  
Instructions for use  
Mode d'emploi  
Modo de empleo



Information  
Information  
Information  
Información

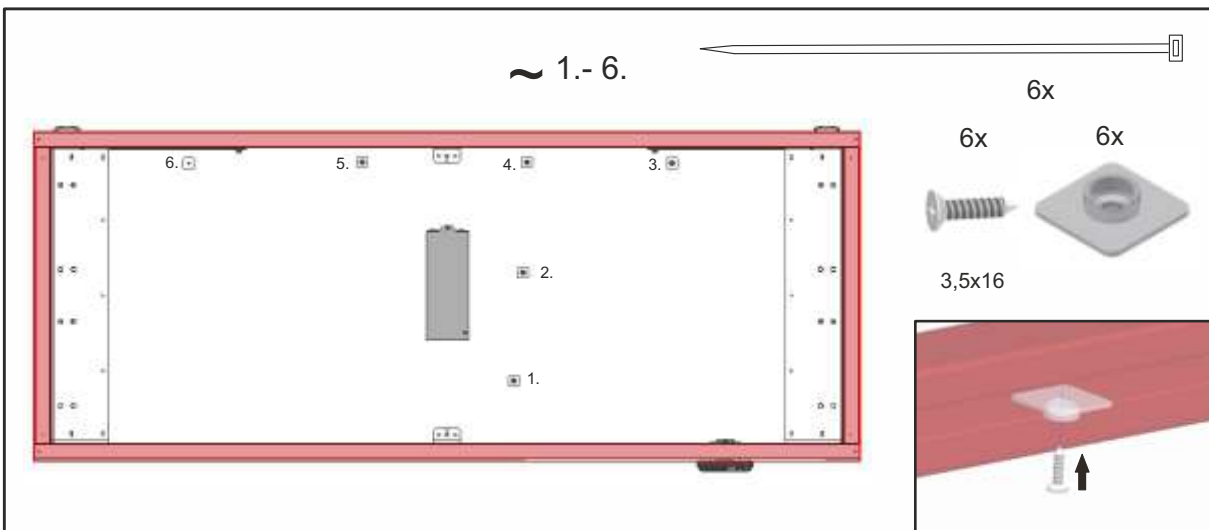
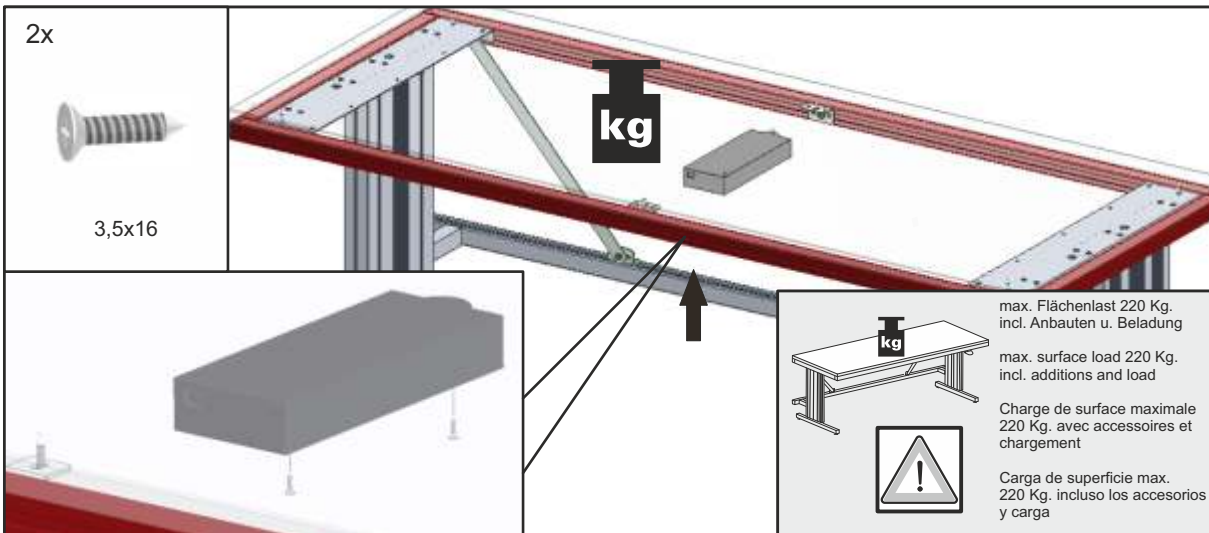





**Montageanleitung**  
 Mounting instructions  
 Instructions de montage  
 Instrucciones de montaje



**Gebrauchsanleitung**  
 Instructions for use  
 Mode d'emploi  
 Modo de empleo



**Achtung**  
 Attention  
 Attention  
 Atención

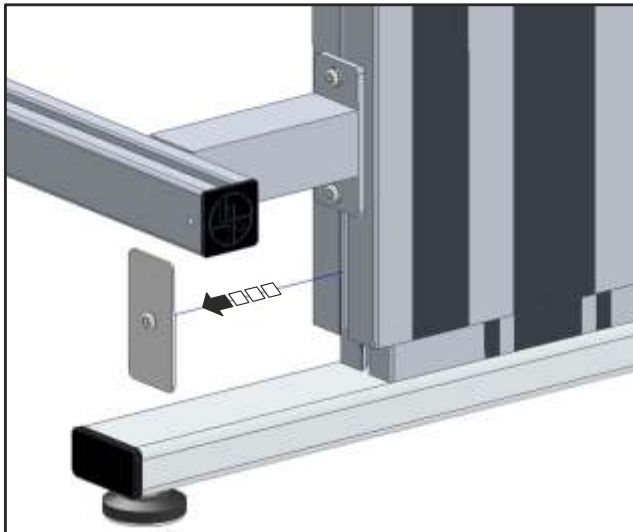

Vor der Erstinbetriebnahme müssen die beiden Einrichthilfen an den Füßen wieder entfernt werden. Die Motoren könnten sonst beschädigt werden.

Before the first initial operation you have to remove once again the two help for setup at the feet. Otherwise it is possible that the motors could be damaged.



73203700

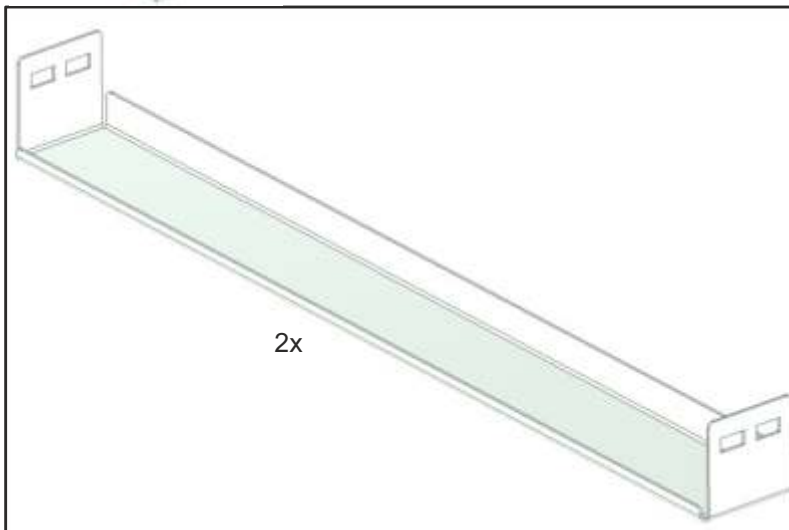
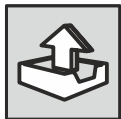

2x

73500020

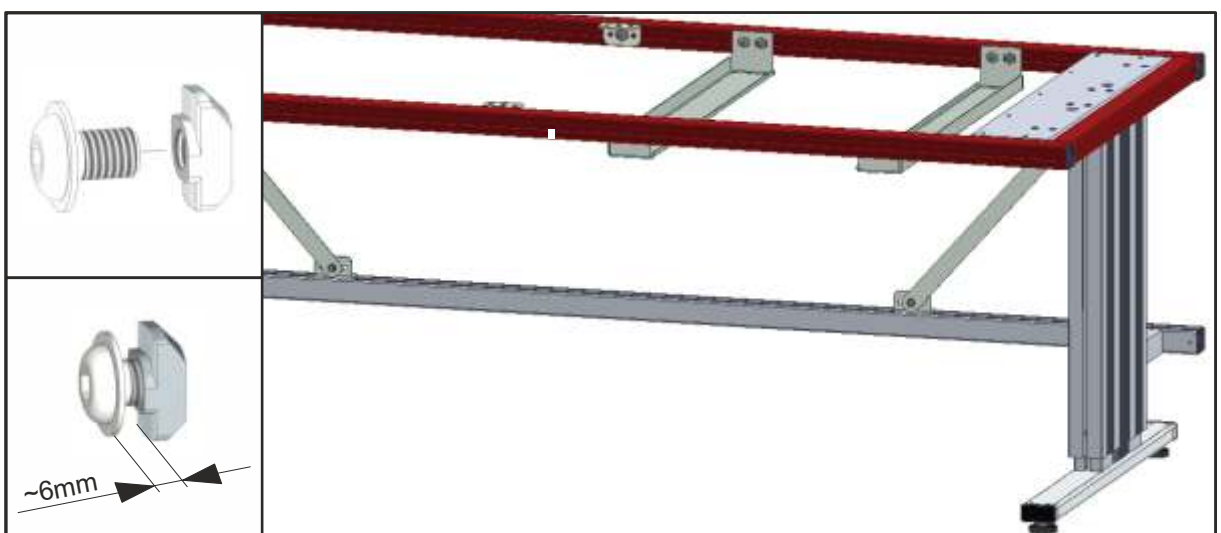



Lieferumfang  
Contents  
Contenu  
Contenido



Montageanleitung  
Mounting instructions  
Instructions de montage  
Instrucciones de montaje



Gebrauchsanleitung  
Instructions for use  
Mode d'emploi  
Modo de empleo

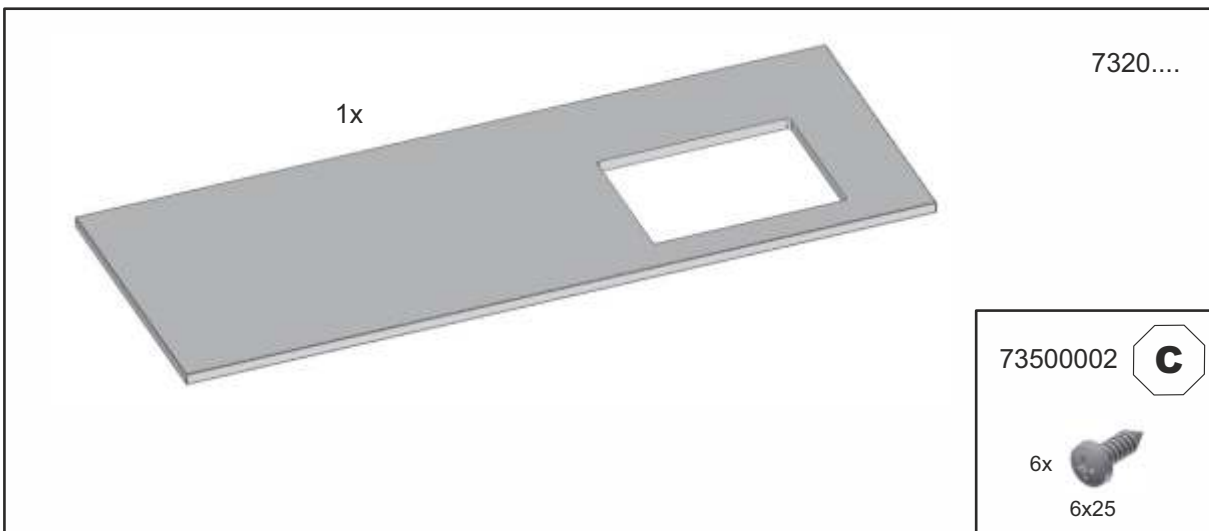
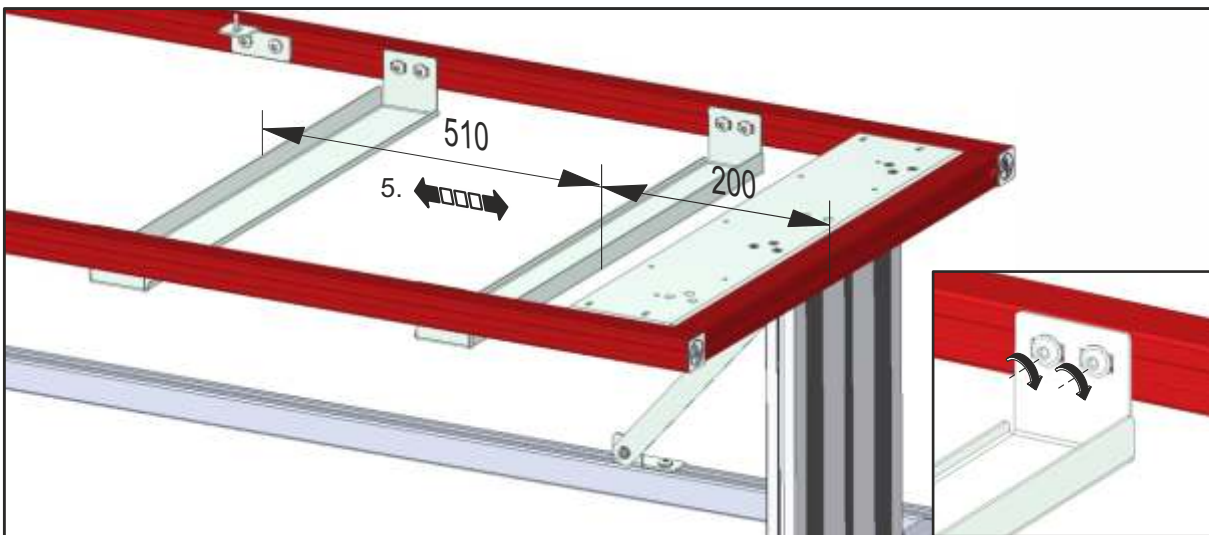
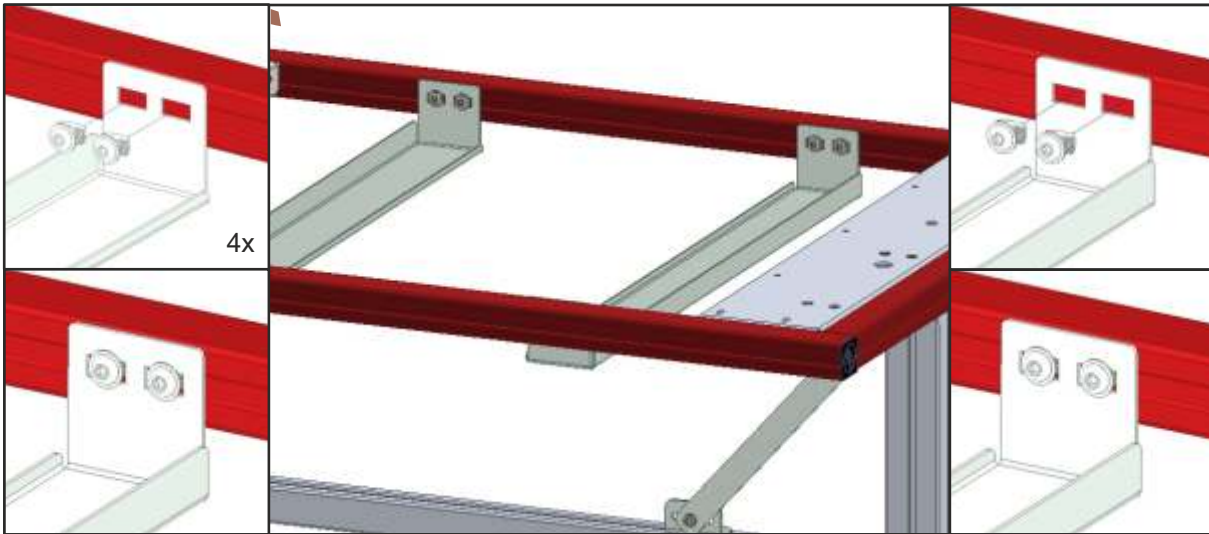



Montageanleitung  
 Mounting instructions  
 Instructions de montage  
 Instrucciones de montaje



Gebrauchsanleitung  
 Instructions for use  
 Mode d'emploi  
 Modo de empleo



2 Personen  
 2 Persons  
 2 Personnes  
 2 Personas



C

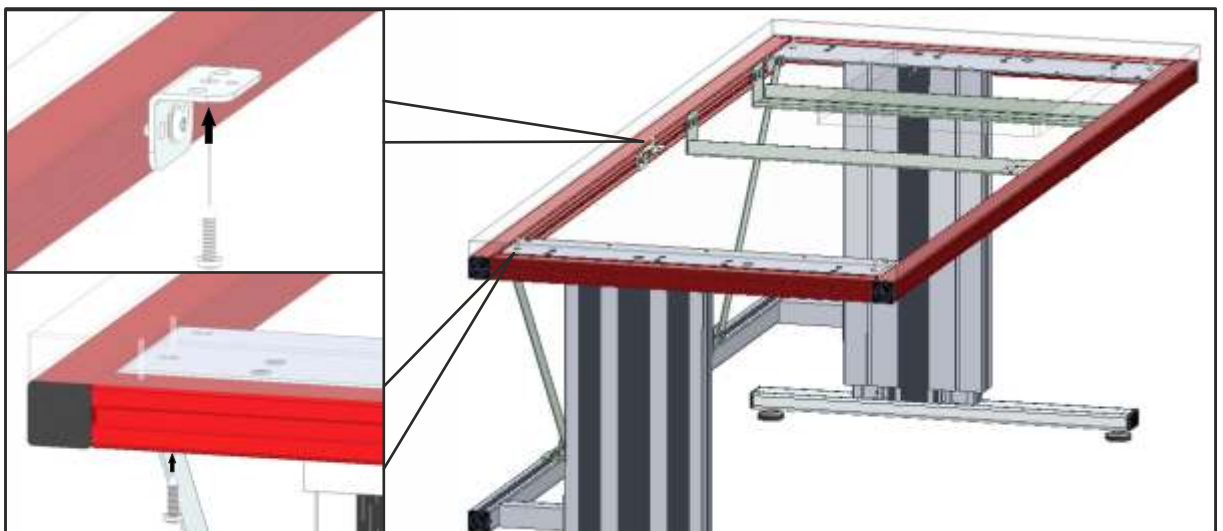



Lieferumfang  
Contents  
Contenu  
Contenido



Montageanleitung  
Mounting instructions  
Instructions de montage  
Instrucciones de montaje



Gebrauchsanleitung  
Instructions for use  
Mode d'emploi  
Modo de empleo

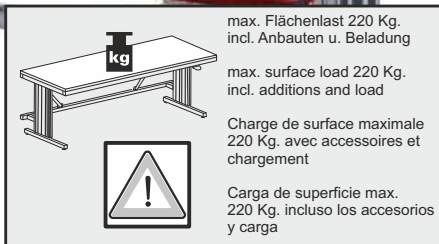
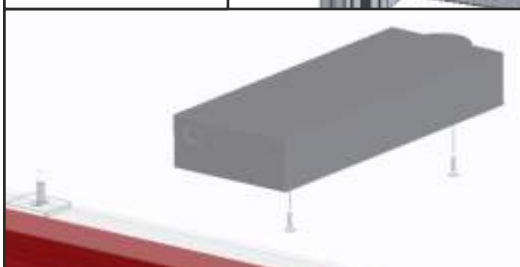
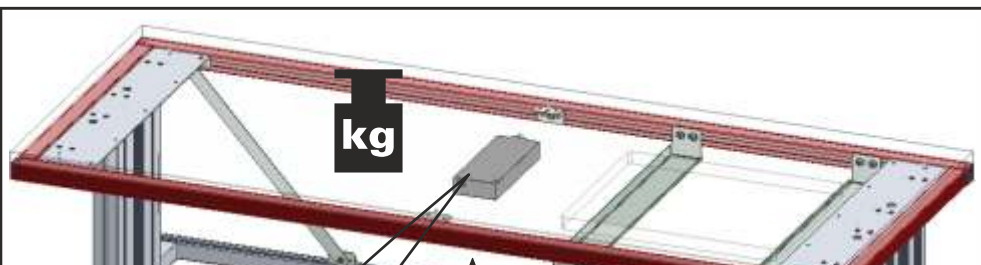
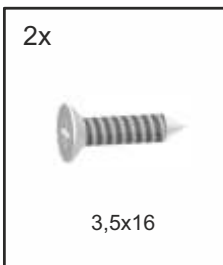
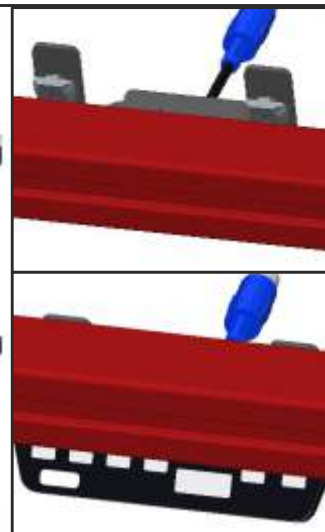
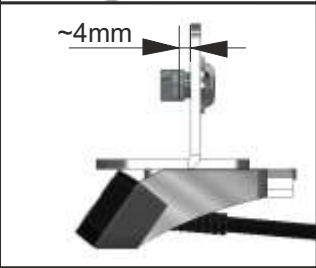
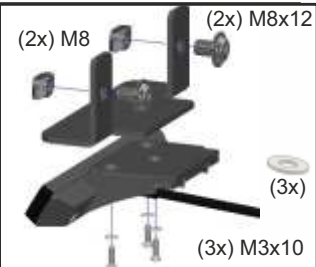





**Montageanleitung**  
 Mounting instructions  
 Instructions de montage  
 Instrucciones de montaje



**Gebrauchsanleitung**  
 Instructions for use  
 Mode d'emploi  
 Modo de empleo



**Achtung**  
 Attention  
 Attention  
 Atención

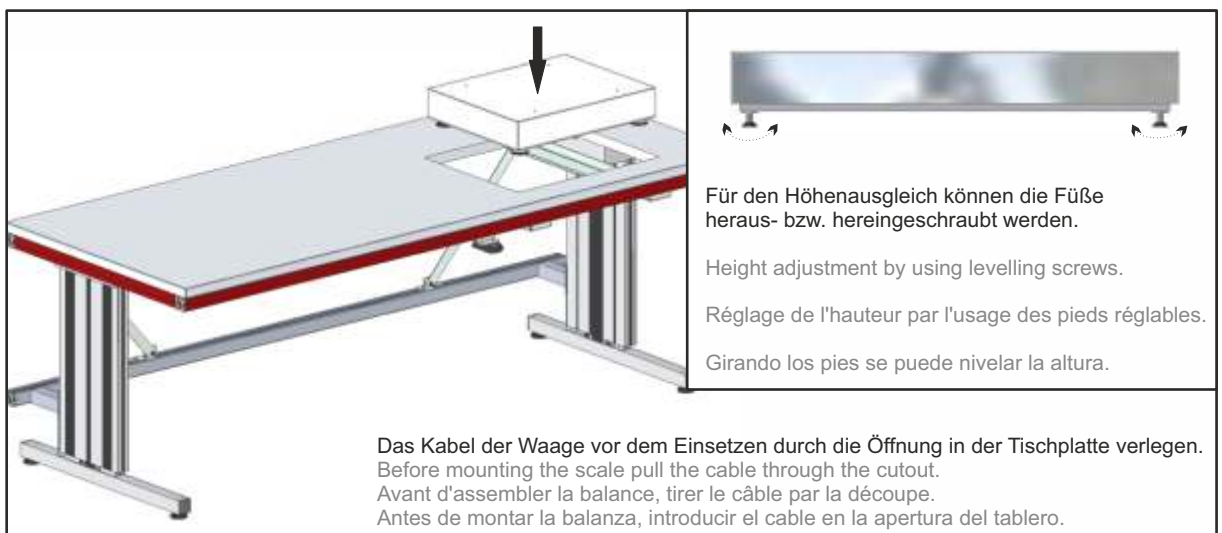
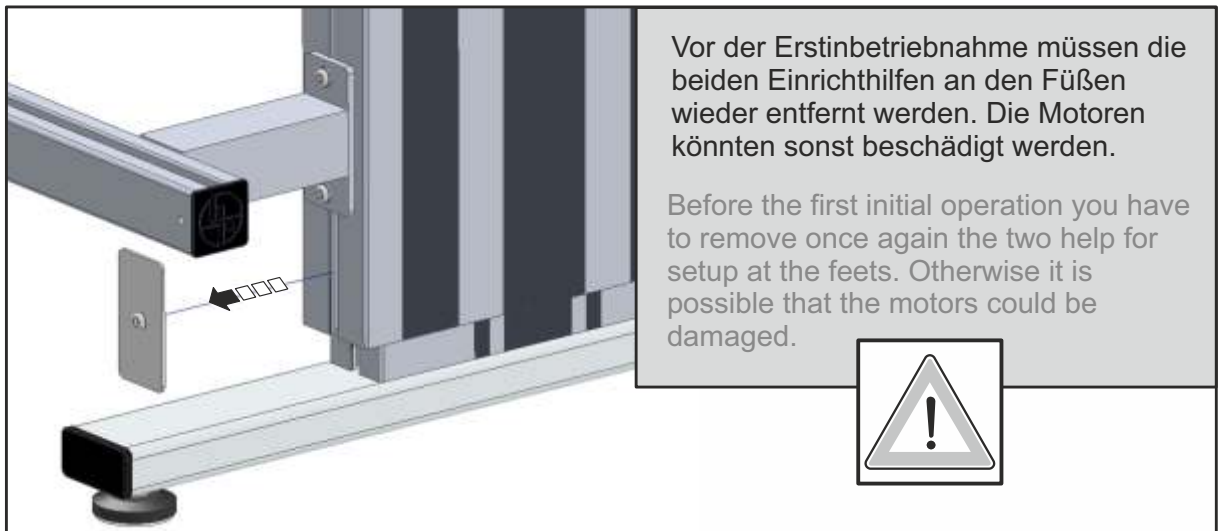
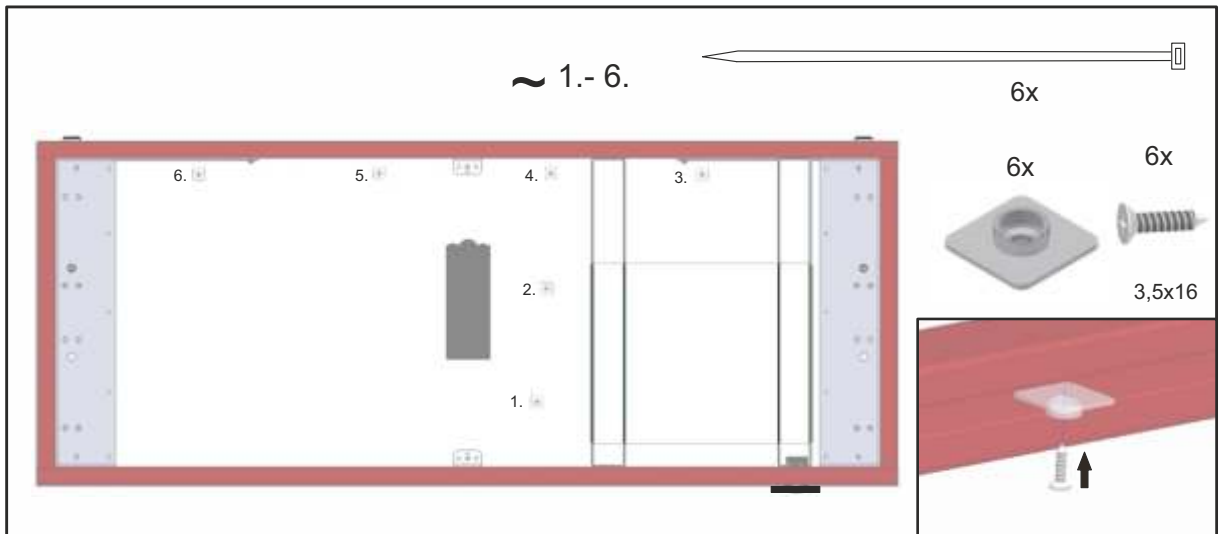





Montageanleitung  
 Mounting instructions  
 Instructions de montage  
 Instrucciones de montaje



Achtung  
 Attention  
 Attention  
 Atención



Information  
 Information  
 Information  
 Información



733022.., 733023.., 733034.., 733055.., 733059.., 733060..

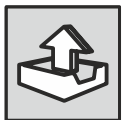
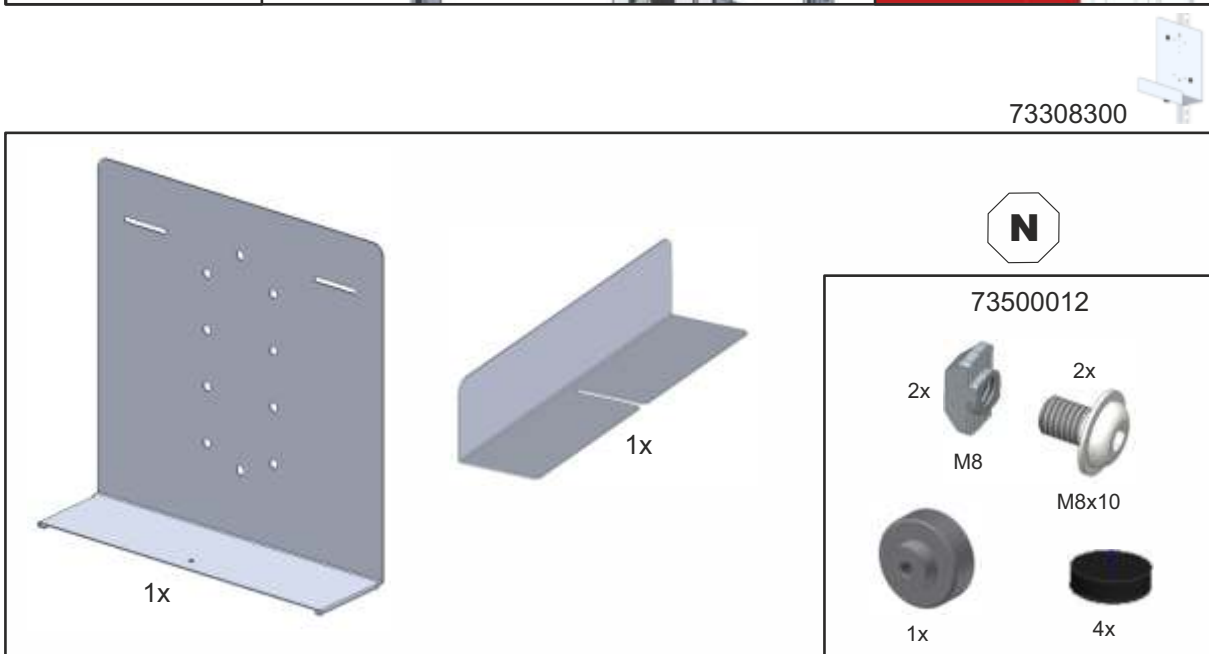
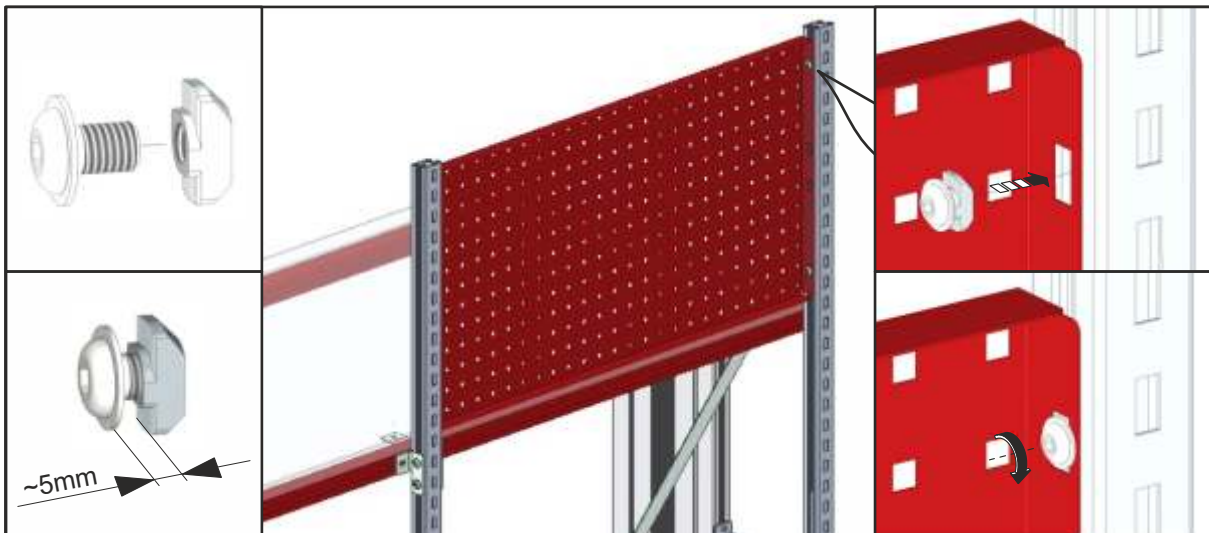
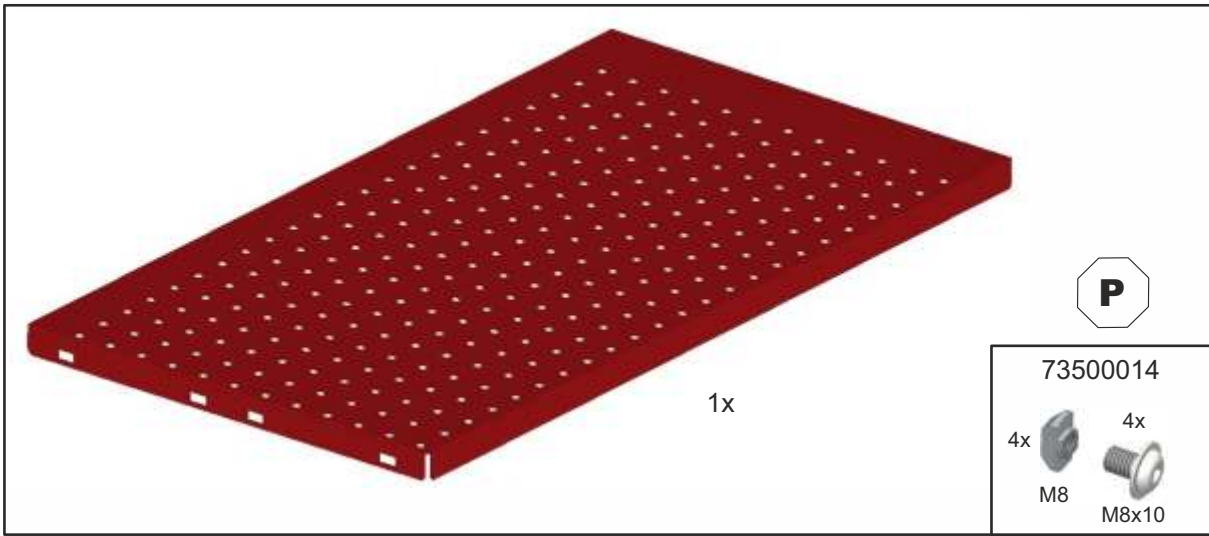
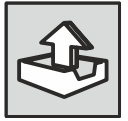



Lieferumfang  
Contents  
Contenu  
Contenido



Montageanleitung  
Mounting instructions  
Instructions de montage  
Instrucciones de montaje



Gebrauchsanleitung  
Instructions for use  
Mode d'emploi  
Modo de empleo



N

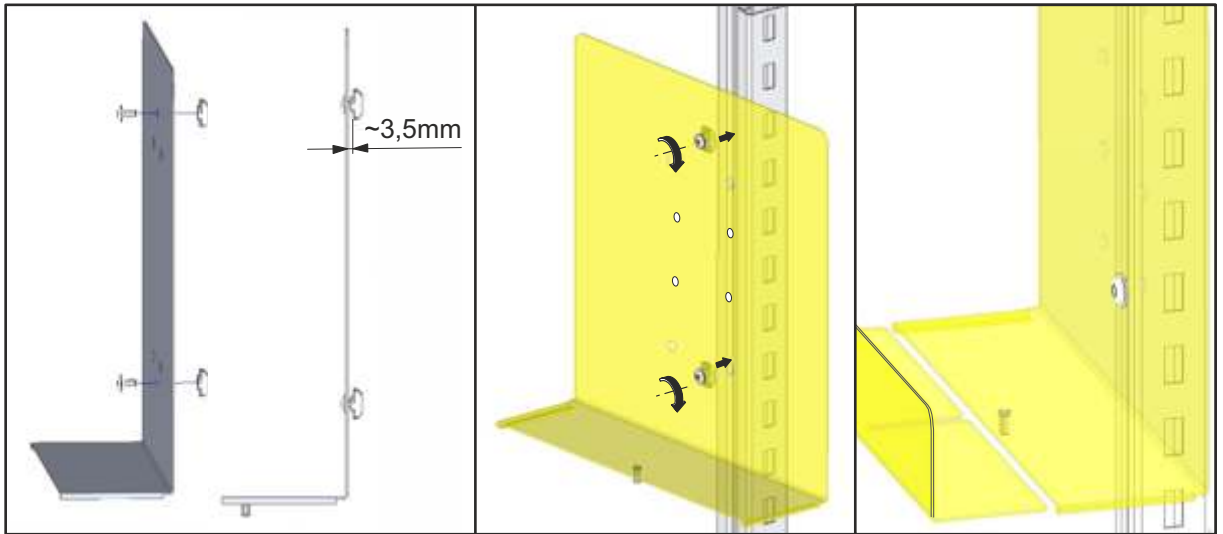

N

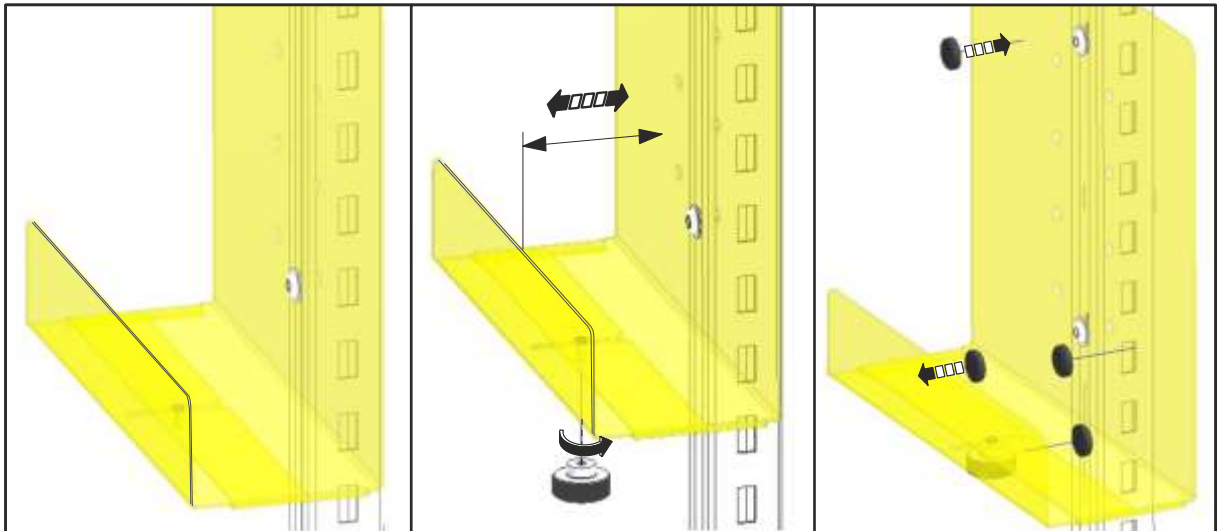

73312500, 73312501, 73312600, 73312601

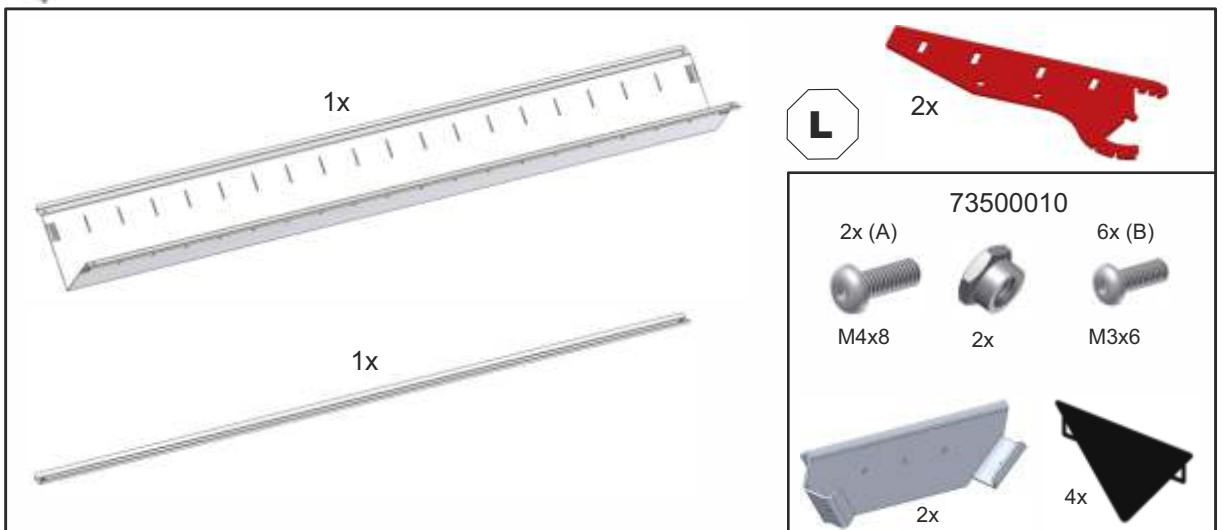

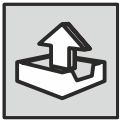

Lieferumfang  
Contents  
Contenu  
Contenido



Montageanleitung  
Mounting instructions  
Instructions de montage  
Instrucciones de montaje



Gebrauchsanleitung  
Instructions for use  
Mode d'emploi  
Modo de empleo

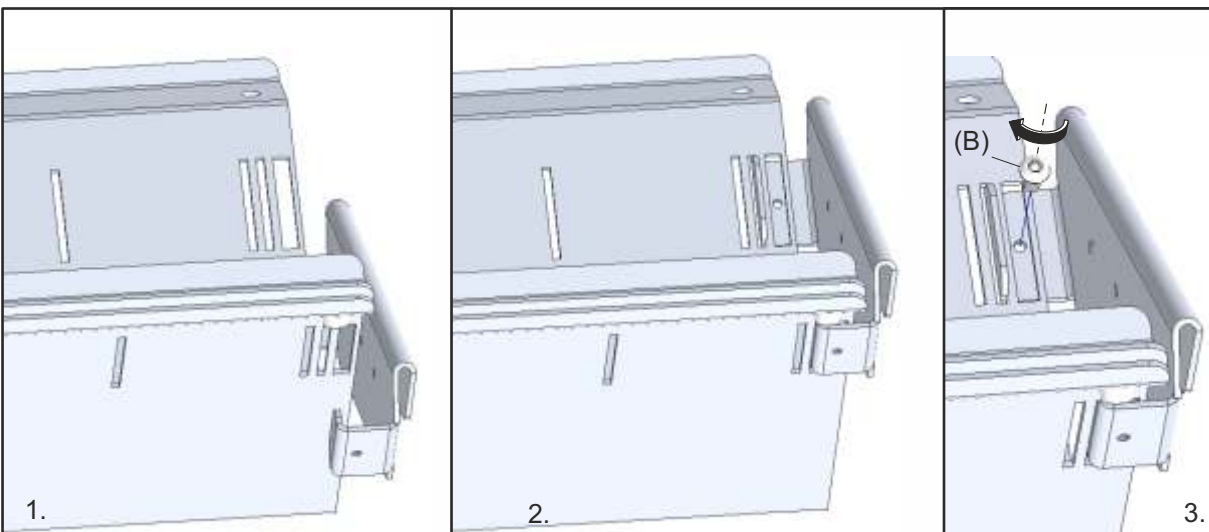
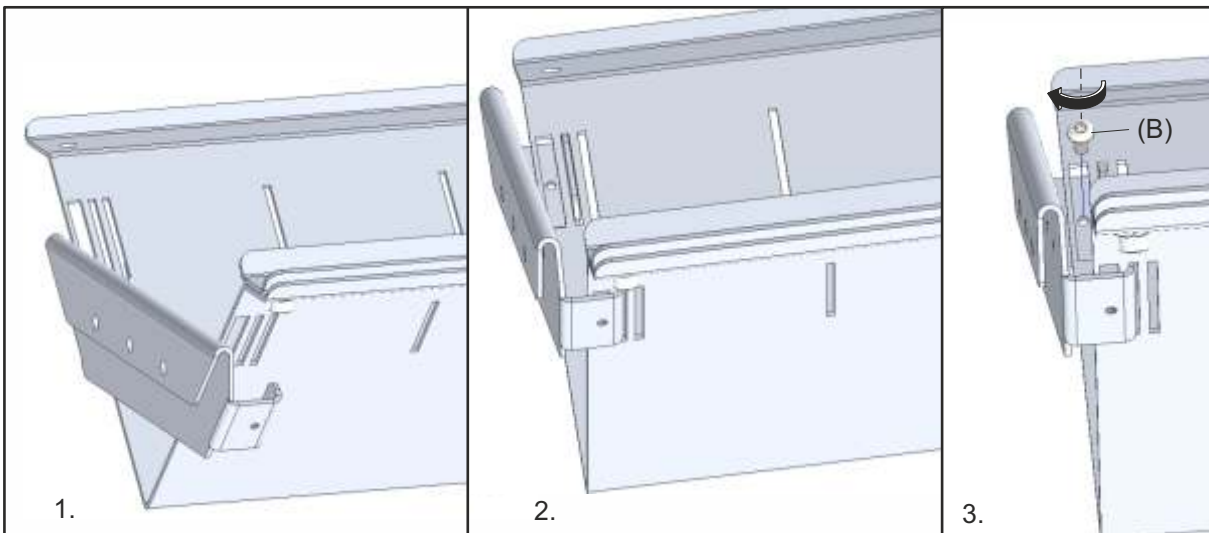
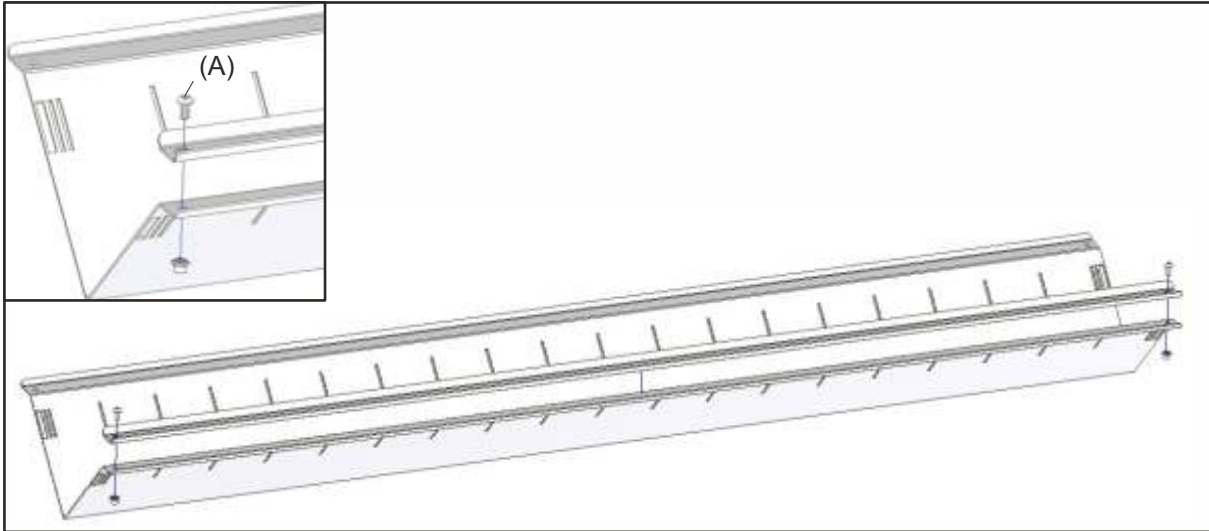

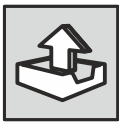

Lieferumfang  
Contents  
Contenu  
Contenido



Montageanleitung  
Mounting instructions  
Instructions de montage  
Instrucciones de montaje



Gebrauchsanleitung  
Instructions for use  
Mode d'emploi  
Modo de empleo

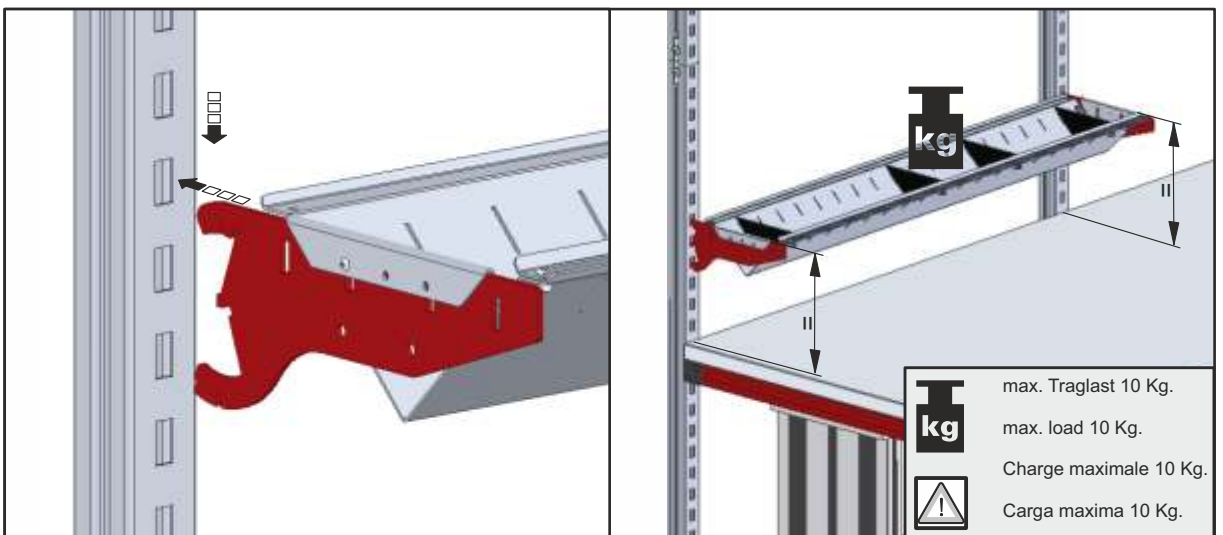
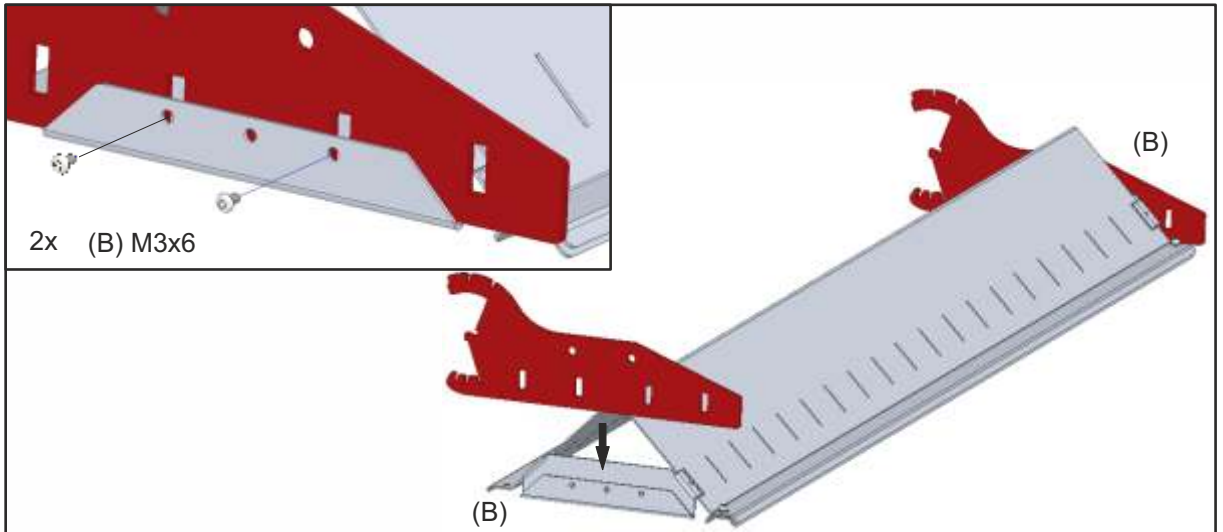

73303000, 73303001, 73303100, 73303101

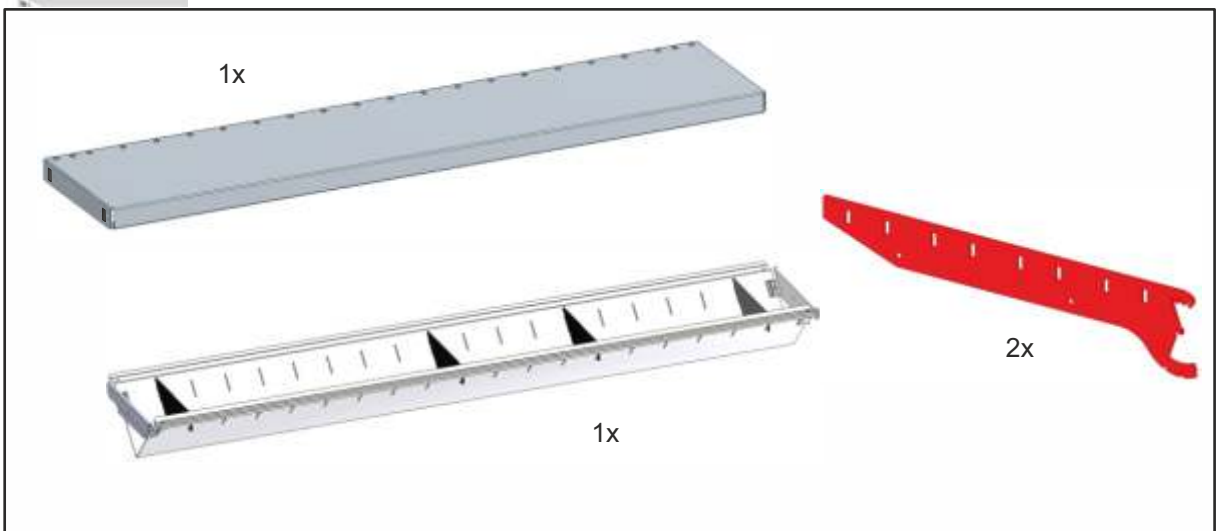
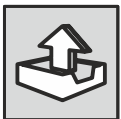



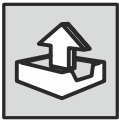

Lieferumfang  
Contents  
Contenu  
Contenido



Montageanleitung  
Mounting instructions  
Instructions de montage  
Instrucciones de montaje



Gebrauchsanleitung  
Instructions for use  
Mode d'emploi  
Modo de empleo

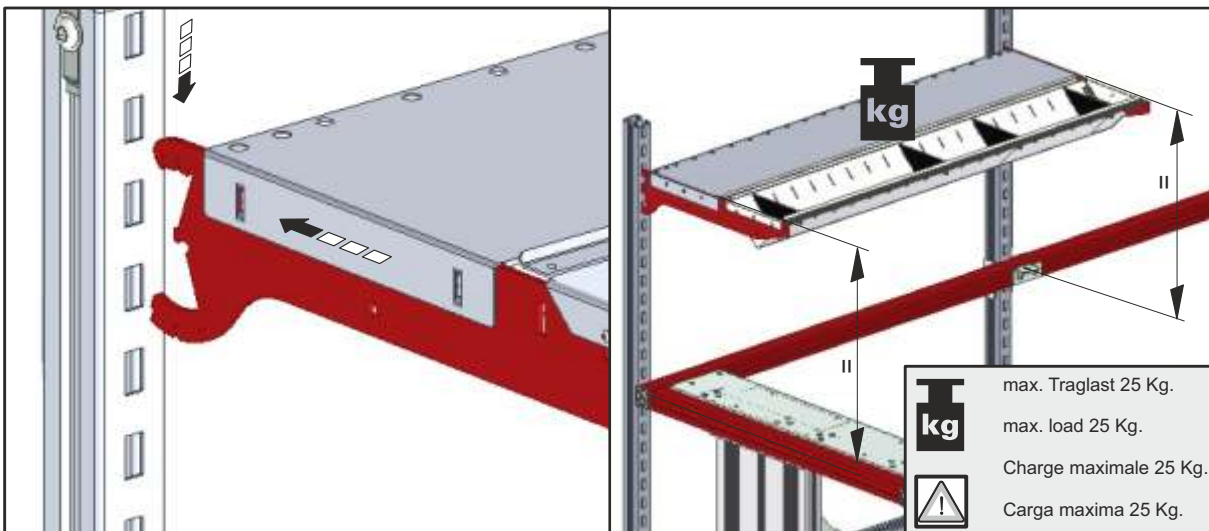
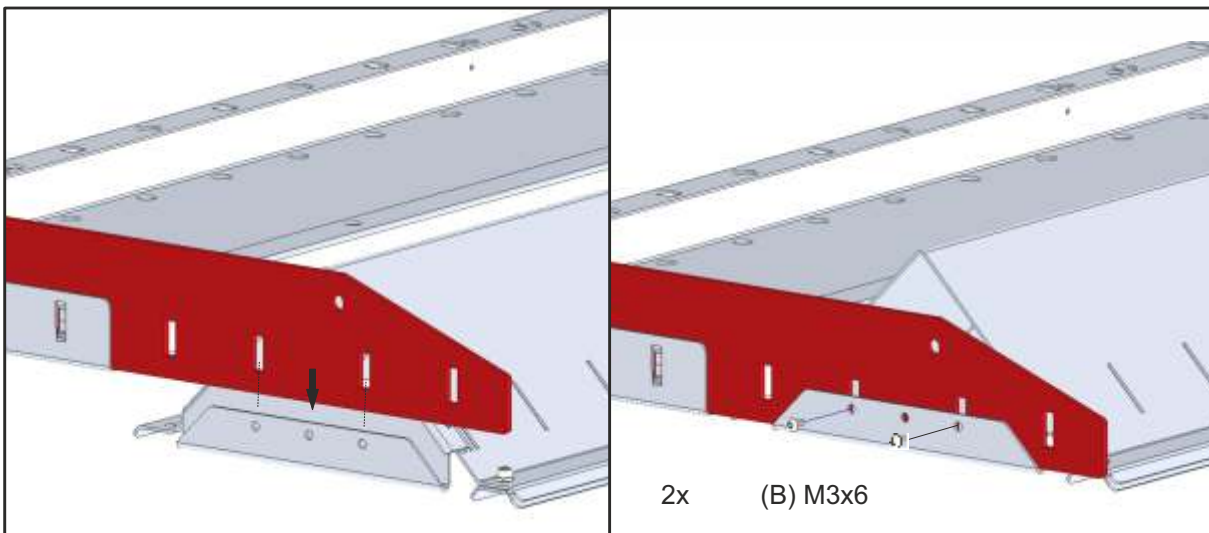
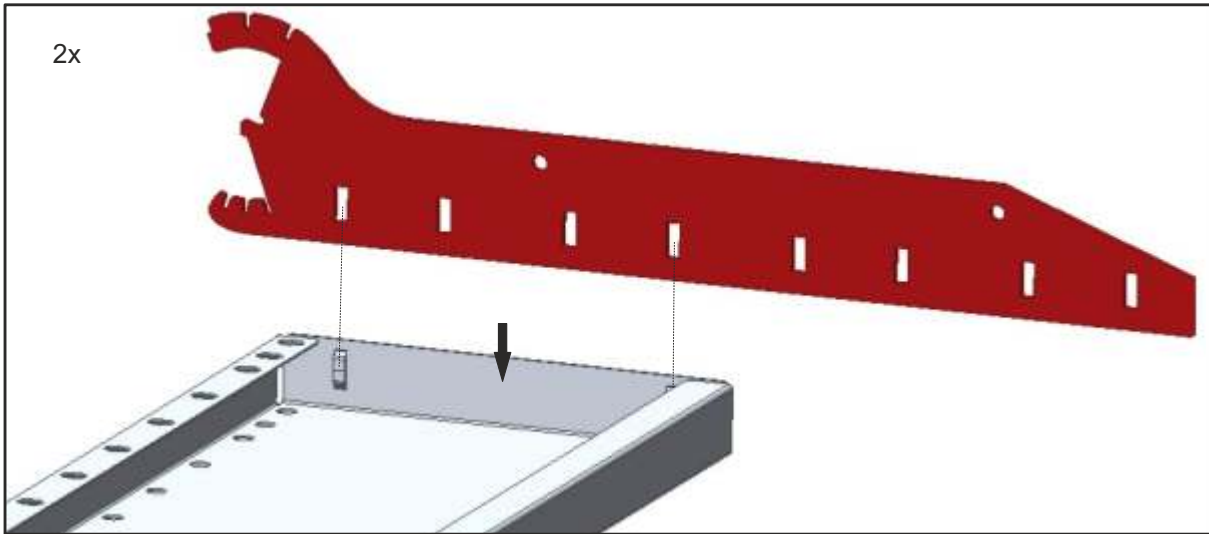

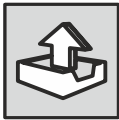

Lieferumfang  
Contents  
Contenu  
Contenido



Montageanleitung  
Mounting instructions  
Instrucciones de montaje  
Instrucciones de montaje



Gebrauchsanleitung  
Instructions for use  
Mode d'emploi  
Modo de empleo



73316500,73316501,73316600,73316601

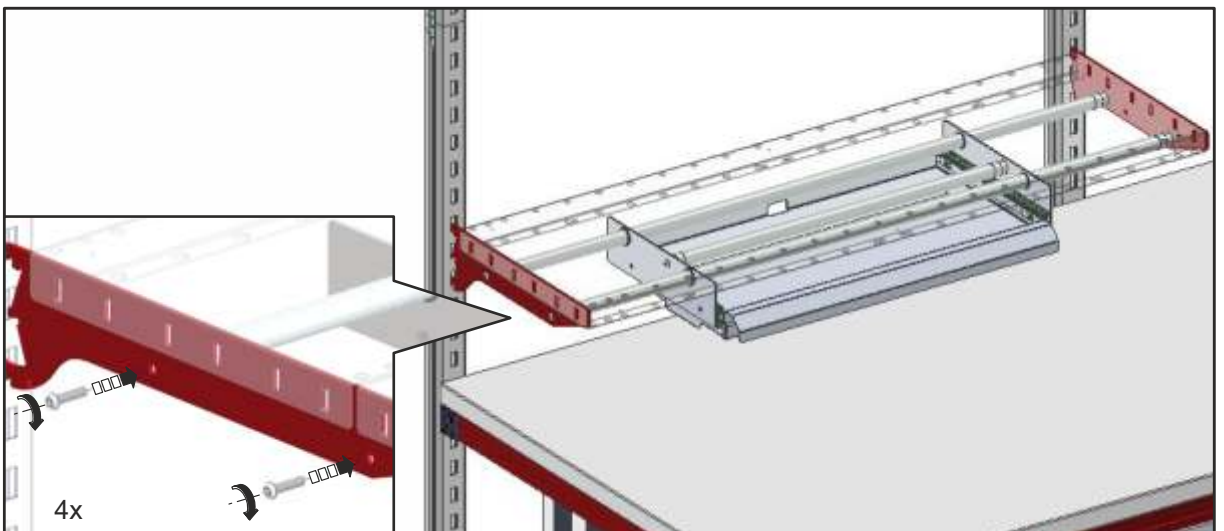
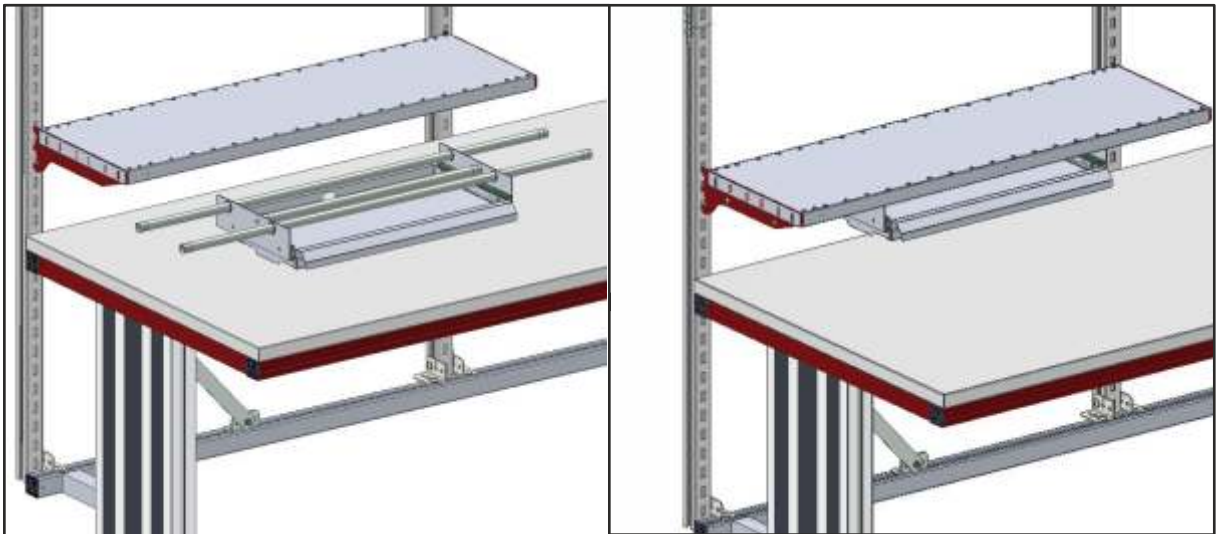
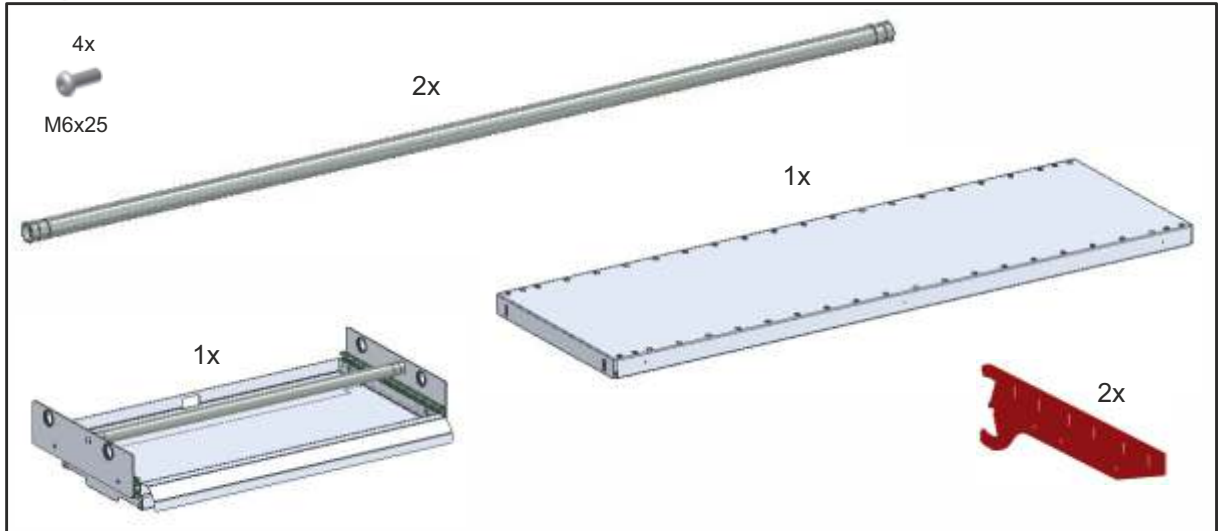
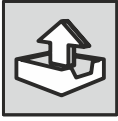

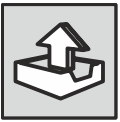

Lieferumfang  
Contents  
Contenu  
Contenido



Montageanleitung  
Mounting instructions  
Instructions de montage  
Instrucciones de montaje



2 Personen  
2 Persons  
2 Personnes  
2 Personas



73308200



73316800

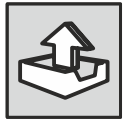
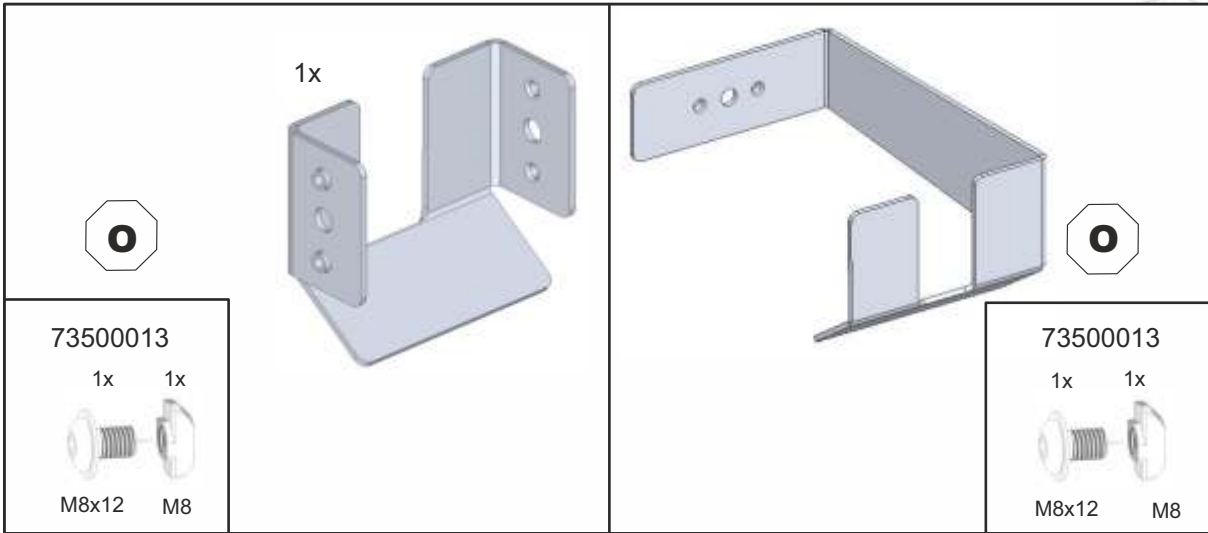

73308200

73316800

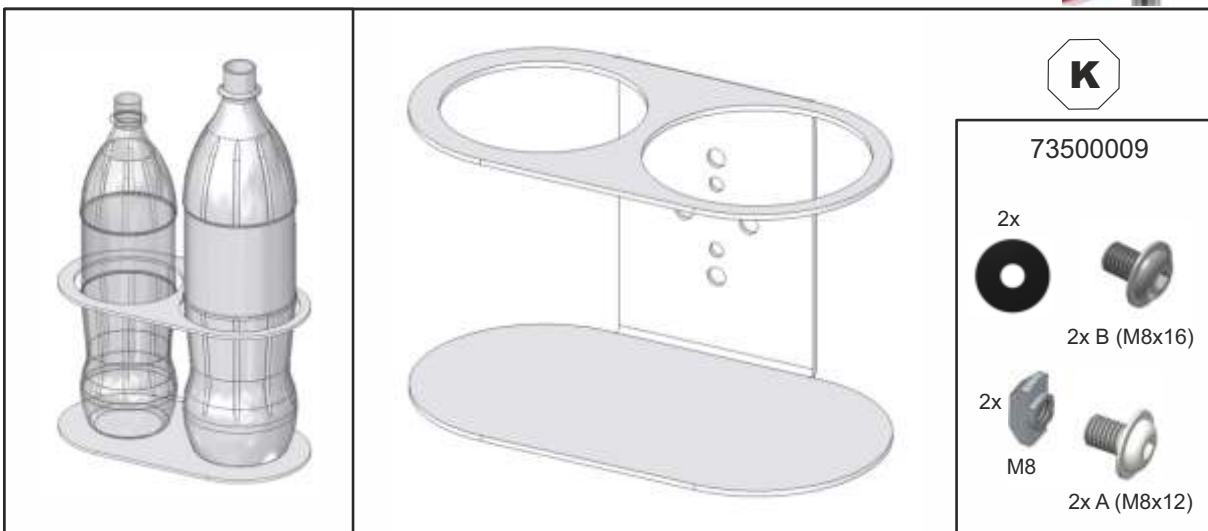
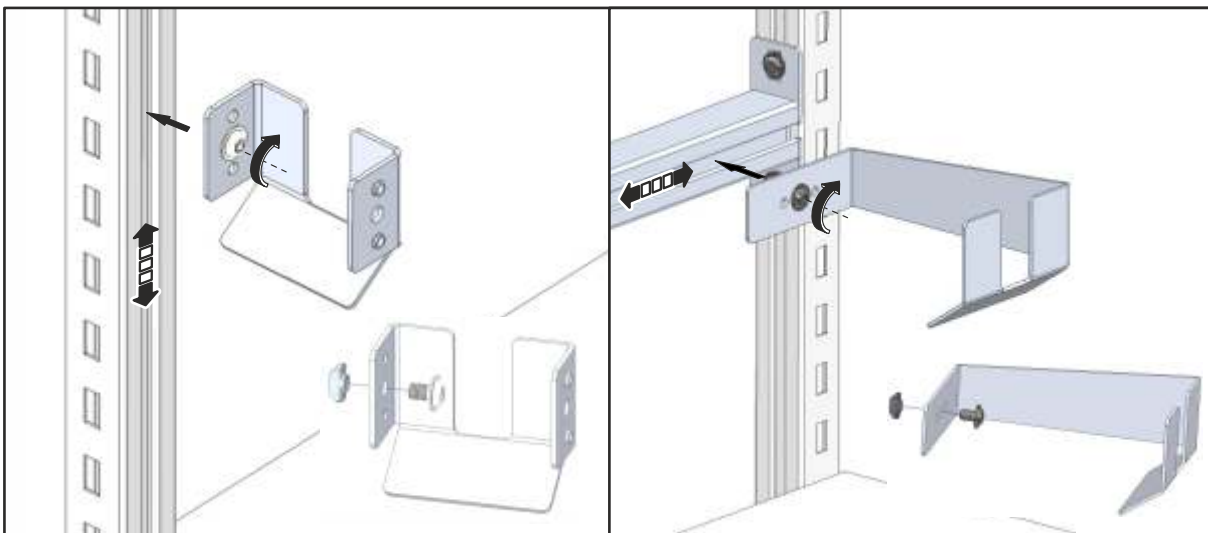

73308500

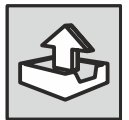

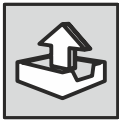

Lieferumfang  
Contents  
Contenu  
Contenido



Montageanleitung  
Mounting instructions  
Instructions de montage  
Instrucciones de montaje



Gebruiksaanleitung  
Instructions for use  
Mode d'emploi  
Modo de empleo



**K**

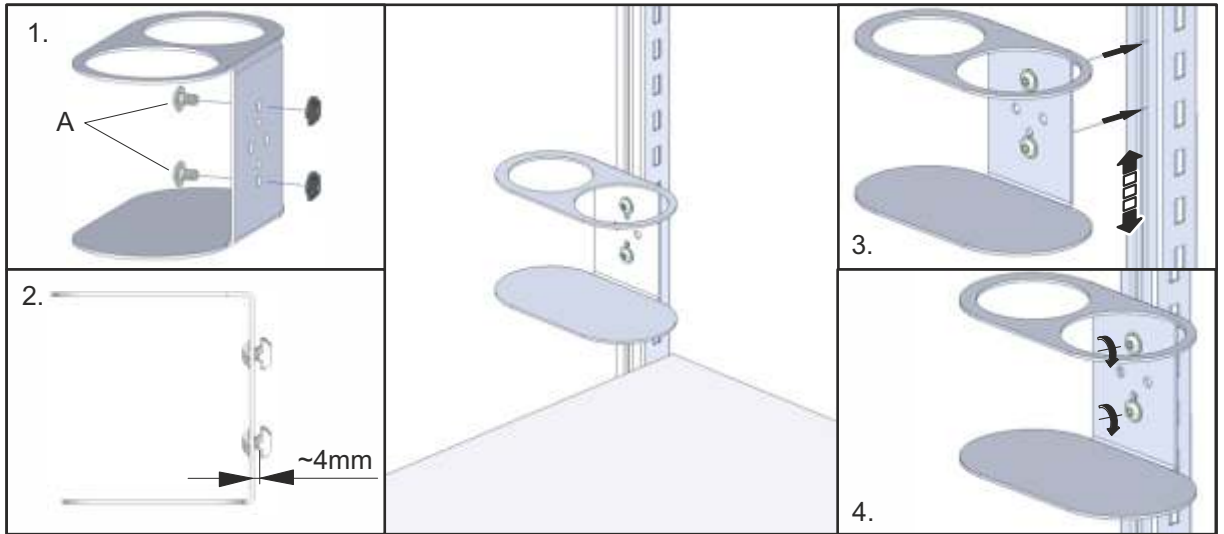

**K**

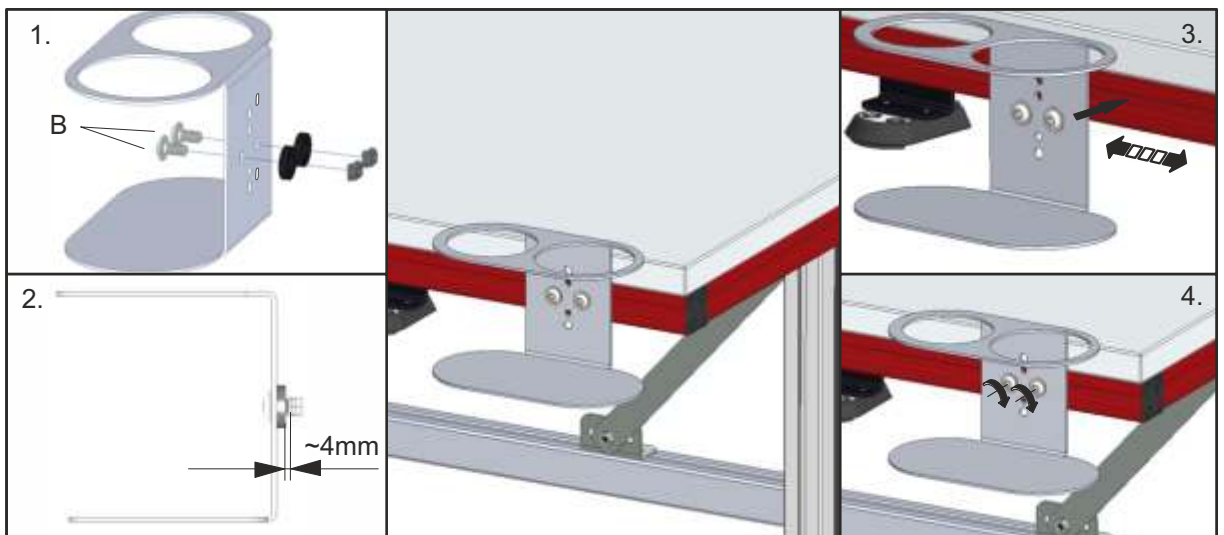

73600026, 73600088

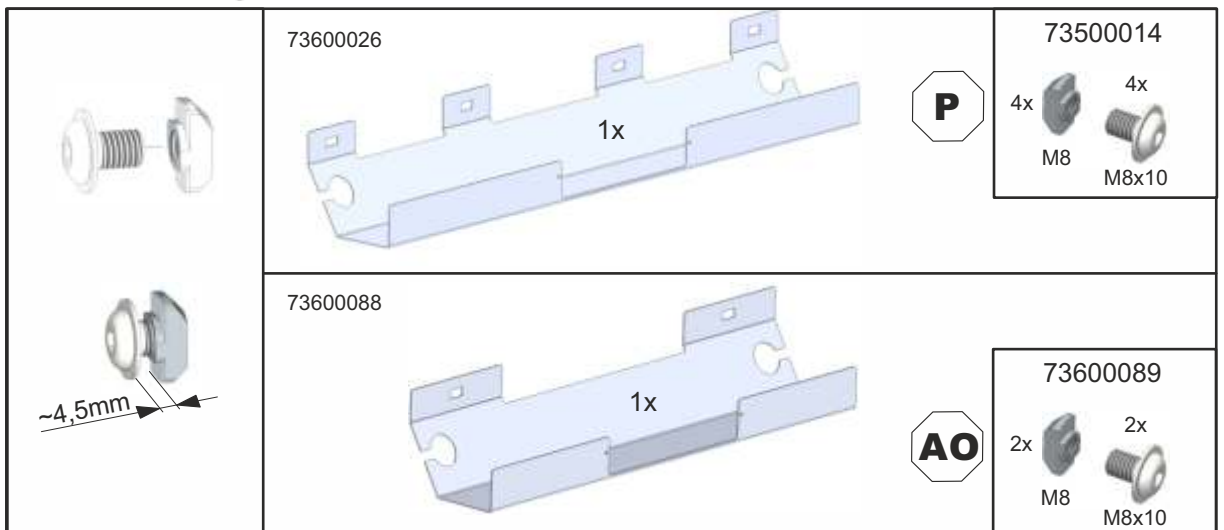
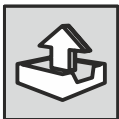



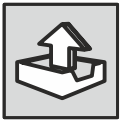

Lieferumfang  
Contents  
Contenu  
Contenido



Montageanleitung  
Mounting instructions  
Instructions de montage  
Instrucciones de montaje



Gebrauchsanleitung  
Instructions for use  
Mode d'emploi  
Modo de empleo

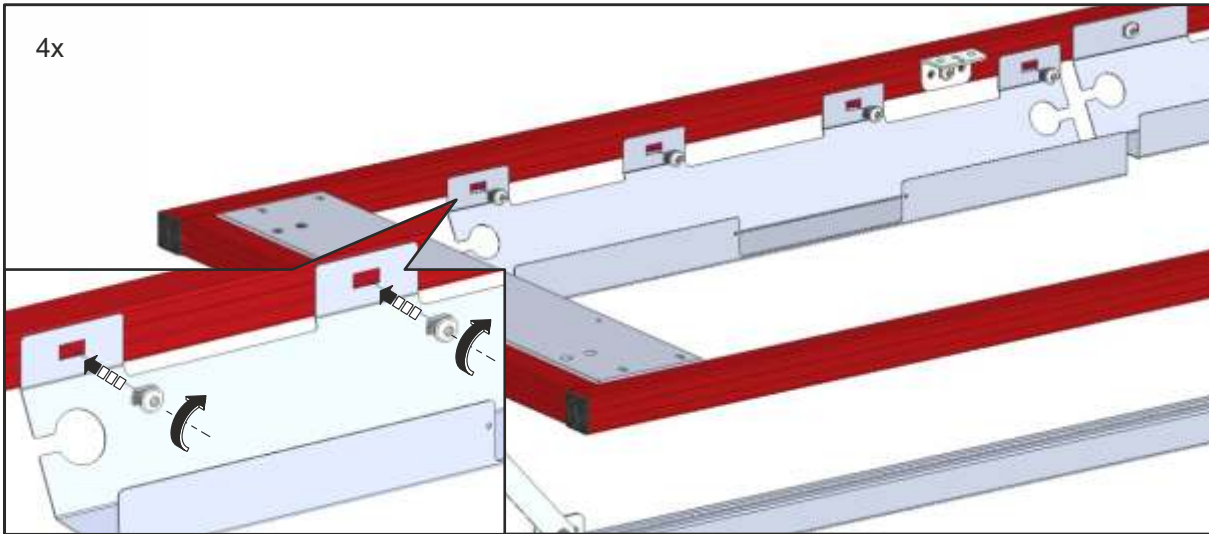

P

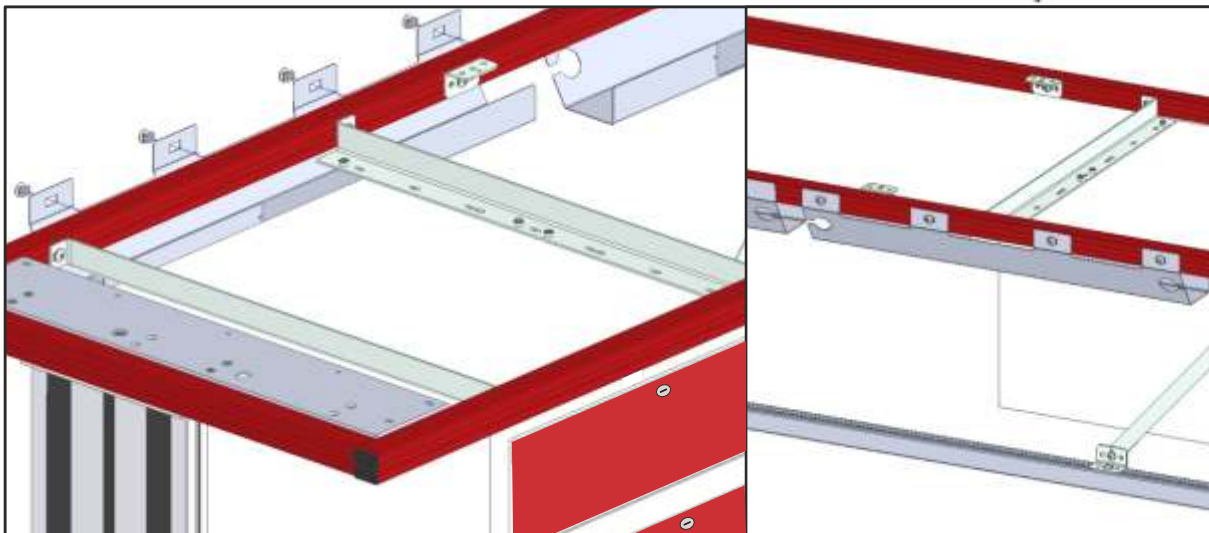

P

Optionales Zubehör / Optional accessories / Accessoires optionnels / Accesorios opcionales

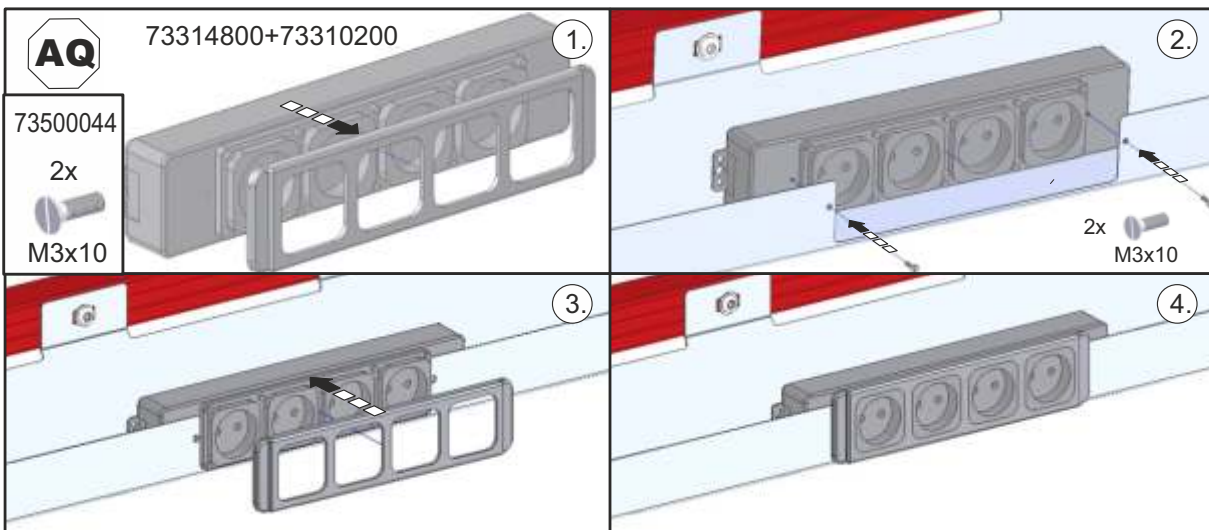

AQ

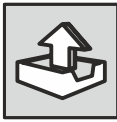

Lieferumfang  
Contents  
Contenu  
Contenido



Montageanleitung  
Mounting instructions  
Instructions de montage  
Instrucciones de montaje



Gebrauchsanleitung  
Instructions for use  
Mode d'emploi  
Modo de empleo



73303900 / 73601254



**R**

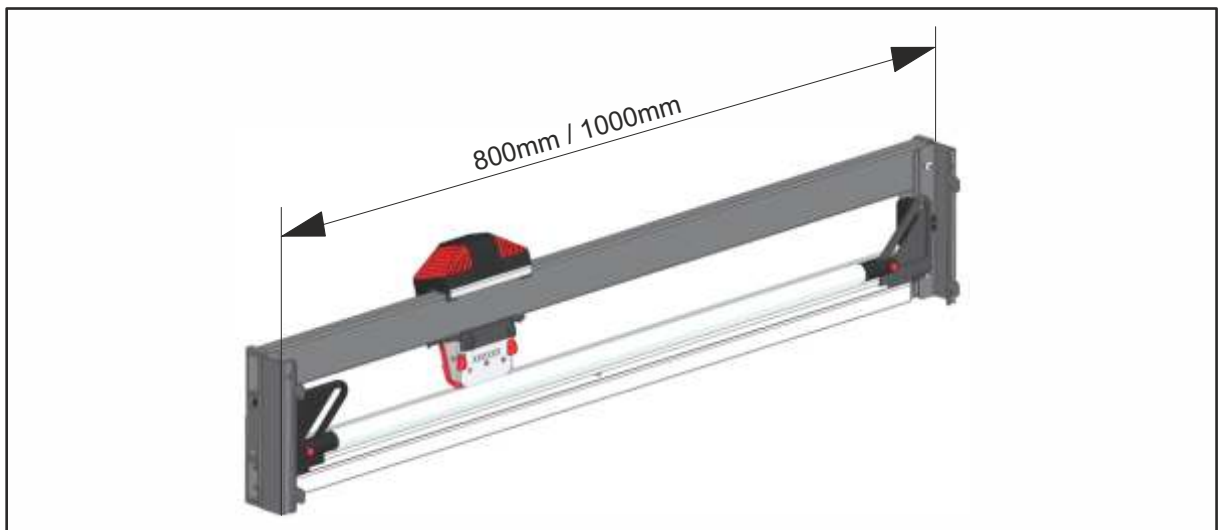

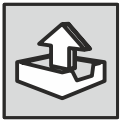

Lieferumfang  
Contents  
Contenu  
Contenido



Montageanleitung  
Mounting instructions  
Instructions de montage  
Instrucciones de montaje



Gebrauchsanleitung  
Instructions for use  
Mode d'emploi  
Modo de empleo

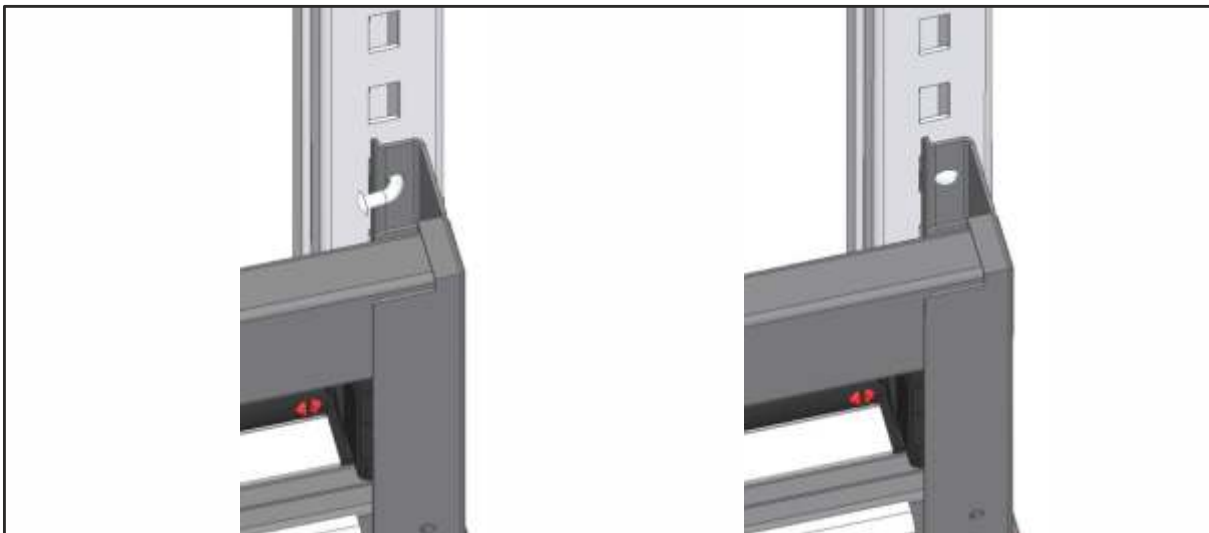
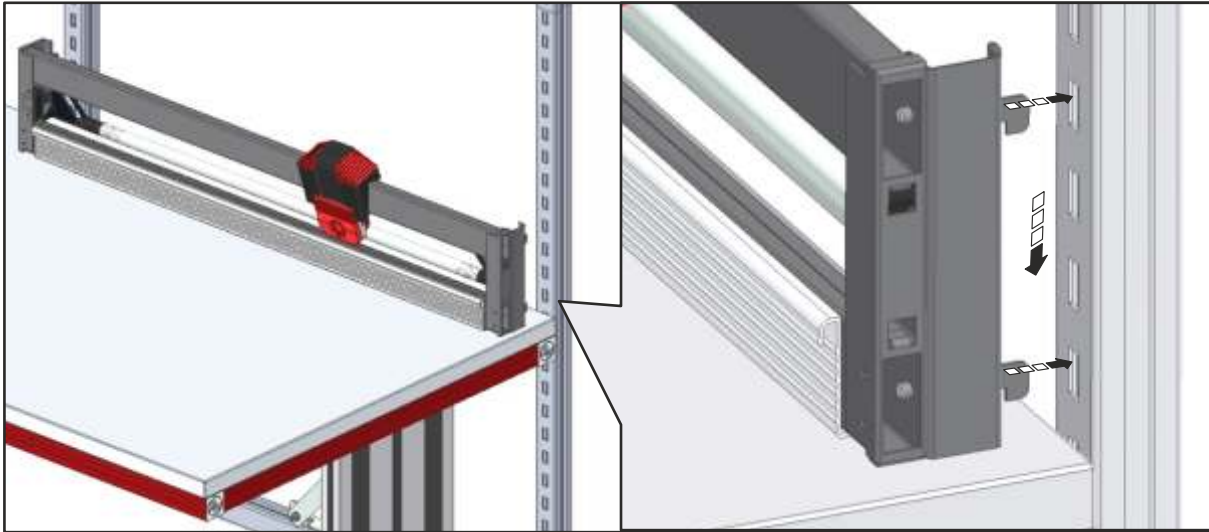

R

73304000 / 73601253

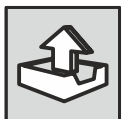
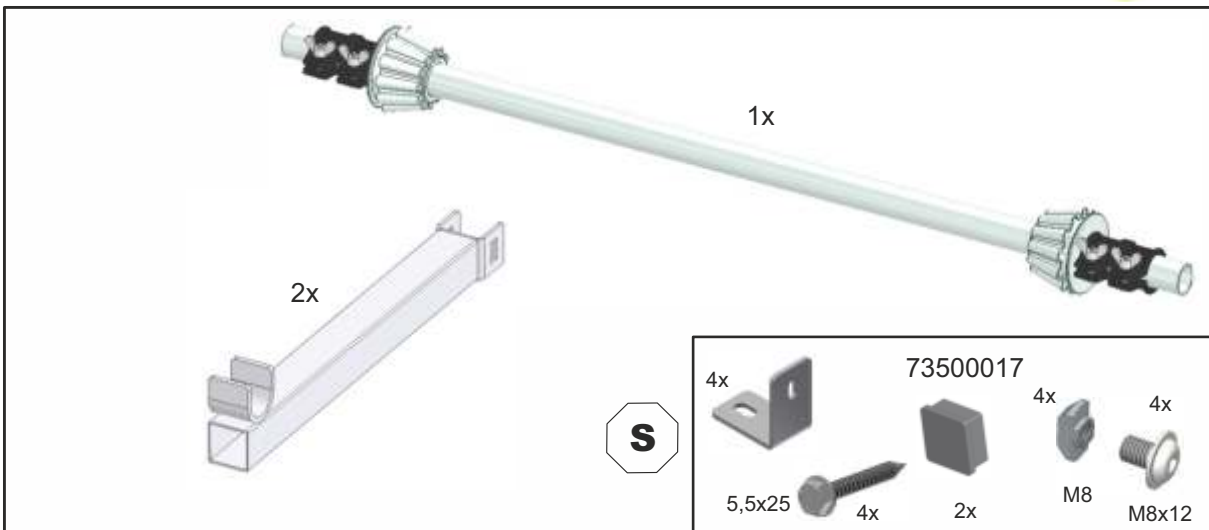

S

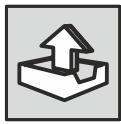

Lieferumfang  
Contents  
Contenu  
Contenido



Montageanleitung  
Mounting instructions  
Instructions de montage  
Instrucciones de montaje



Gebrauchsanleitung  
Instructions for use  
Mode d'emploi  
Modo de empleo



S

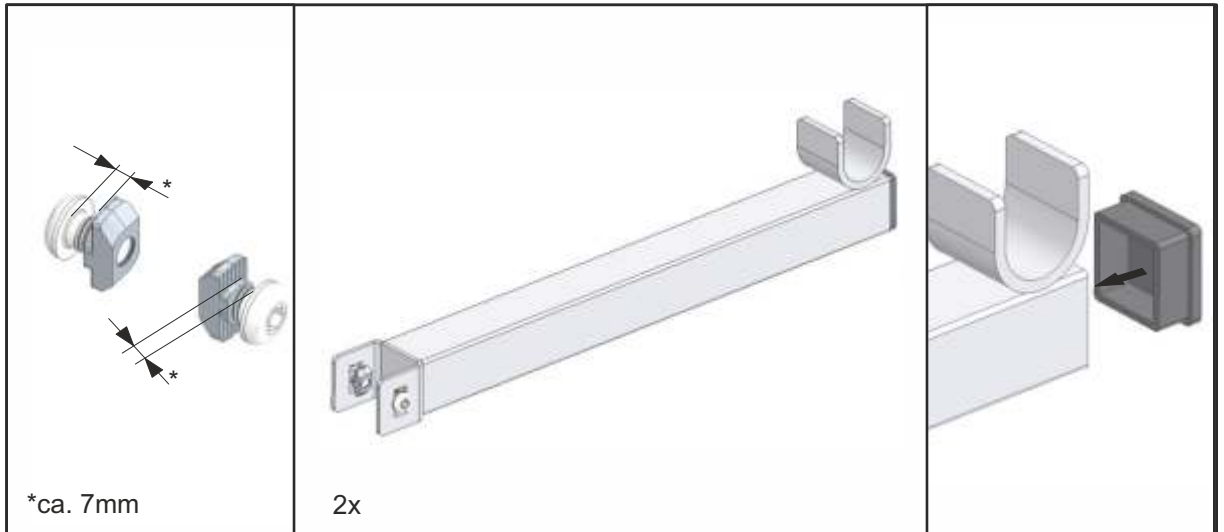

S

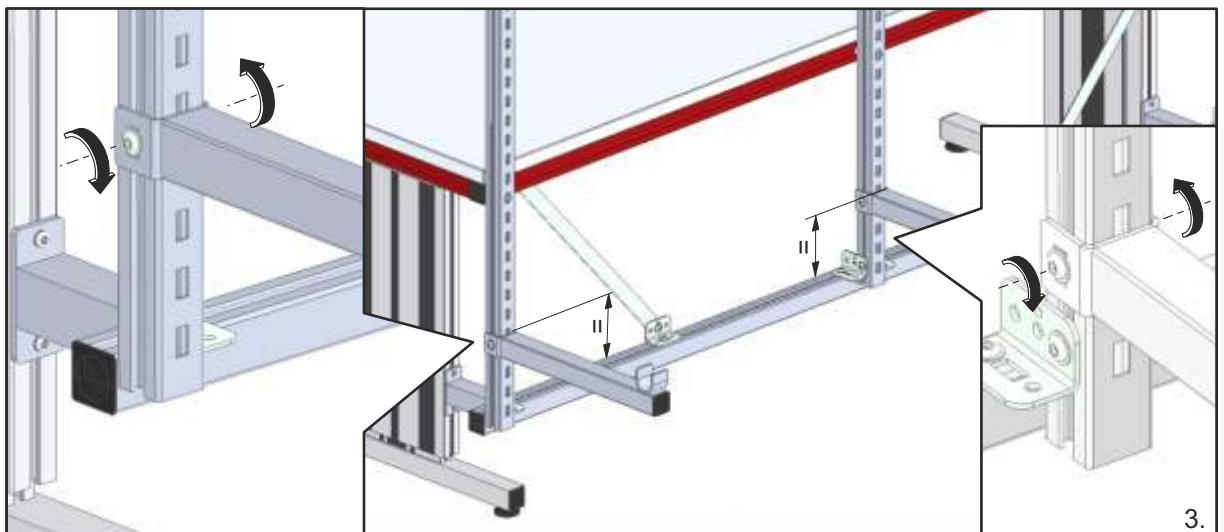
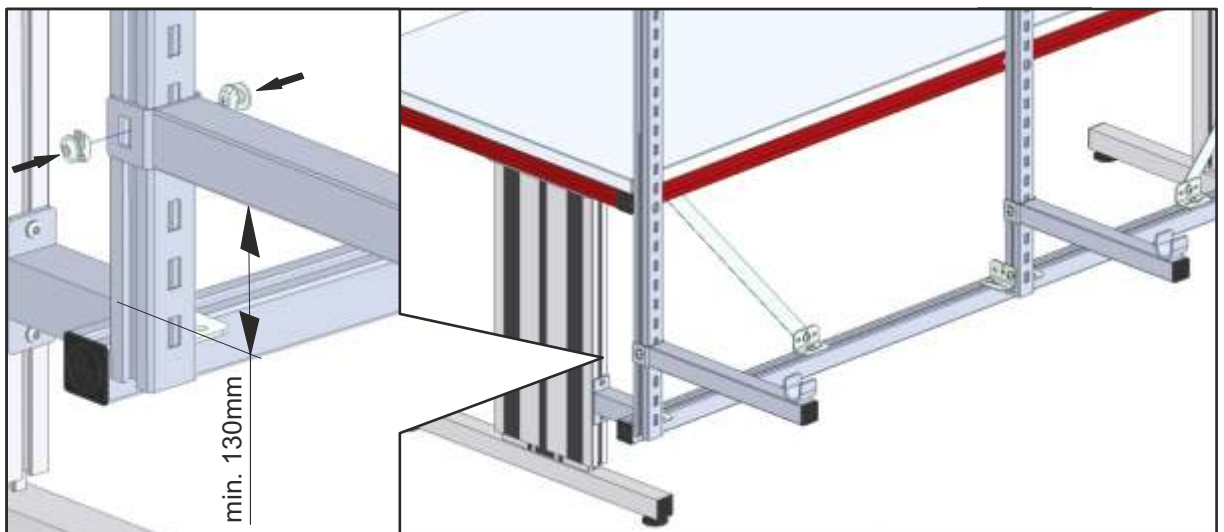





**Montageanleitung**  
 Mounting instructions  
 Instructions de montage  
 Instrucciones de montaje



**Gebrauchsanleitung**  
 Instructions for use  
 Mode d'emploi  
 Modo de empleo



**2 Personen**  
 2 Persons  
 2 Personnes  
 2 Personas

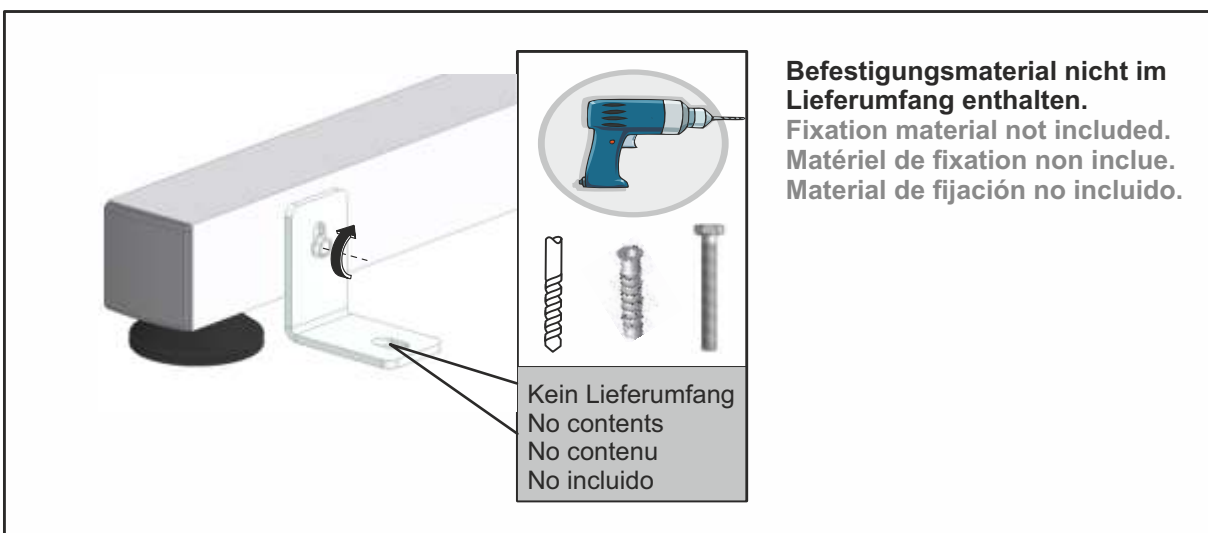
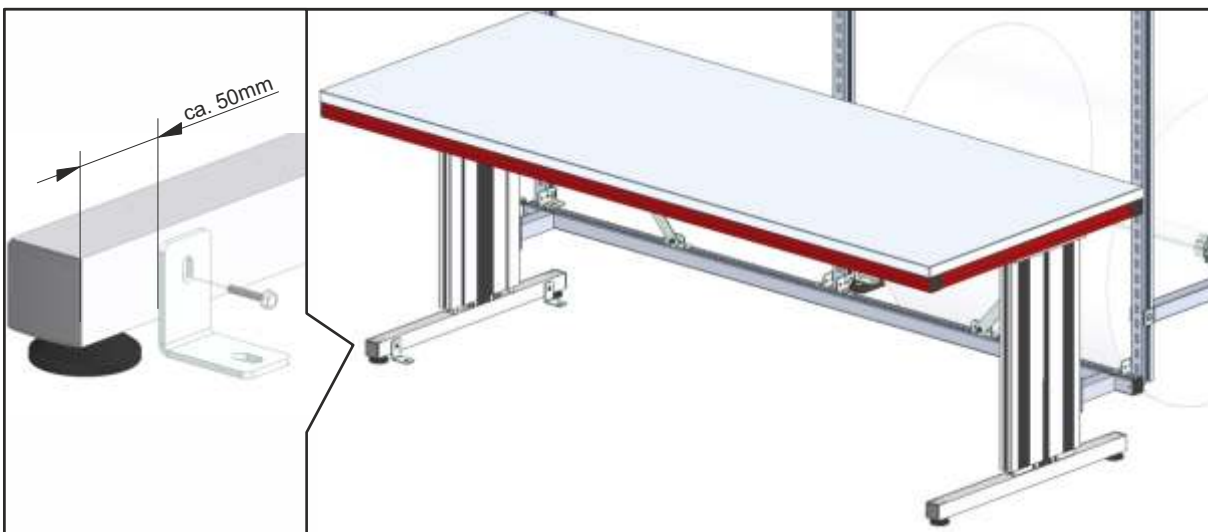
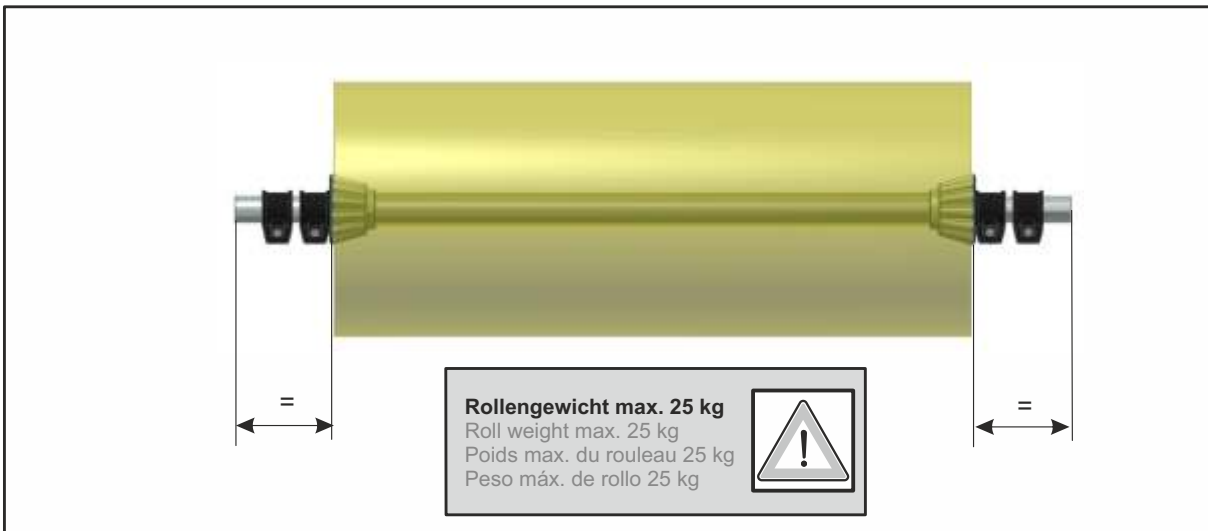

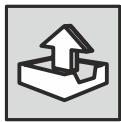

Lieferumfang  
Contents  
Contenu  
Contenido



Montageanleitung  
Mounting instructions  
Instructions de montage  
Instrucciones de montaje



Gebrauchsanleitung  
Instructions for use  
Mode d'emploi  
Modo de empleo



73312000, 73312100

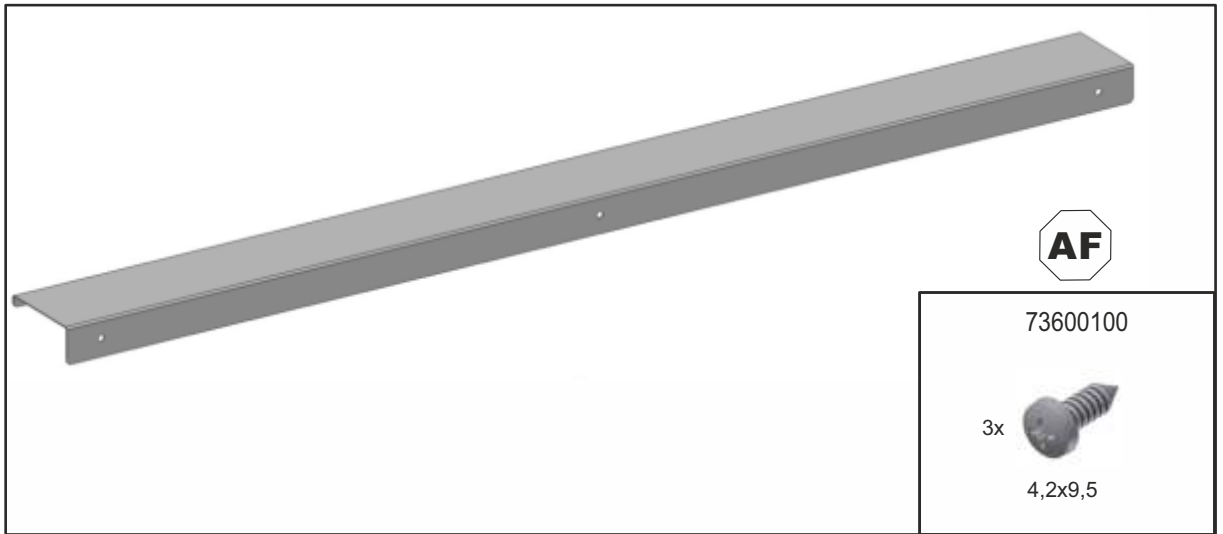
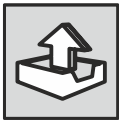

**AF**

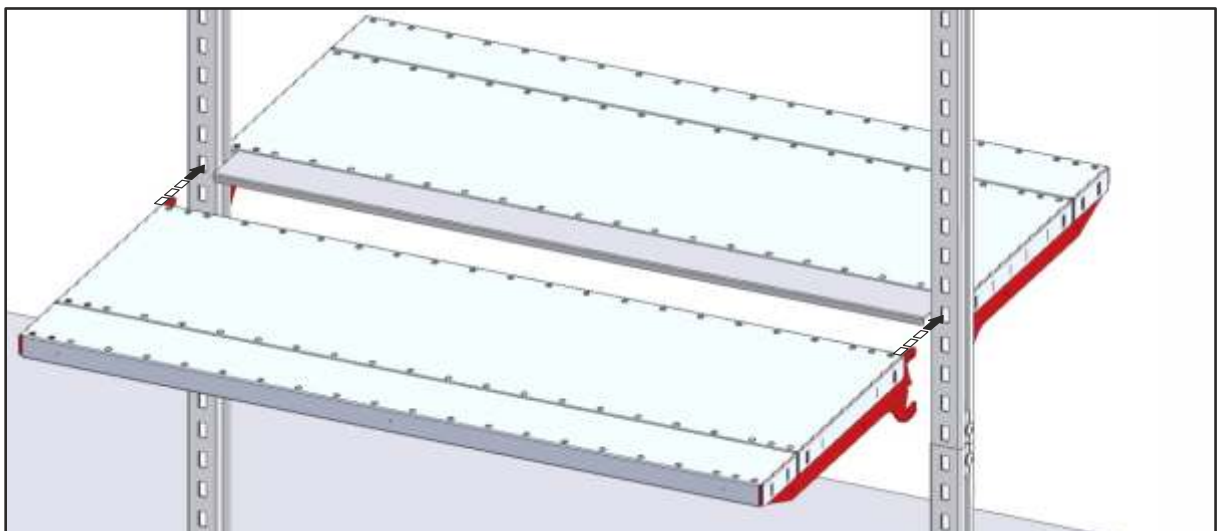
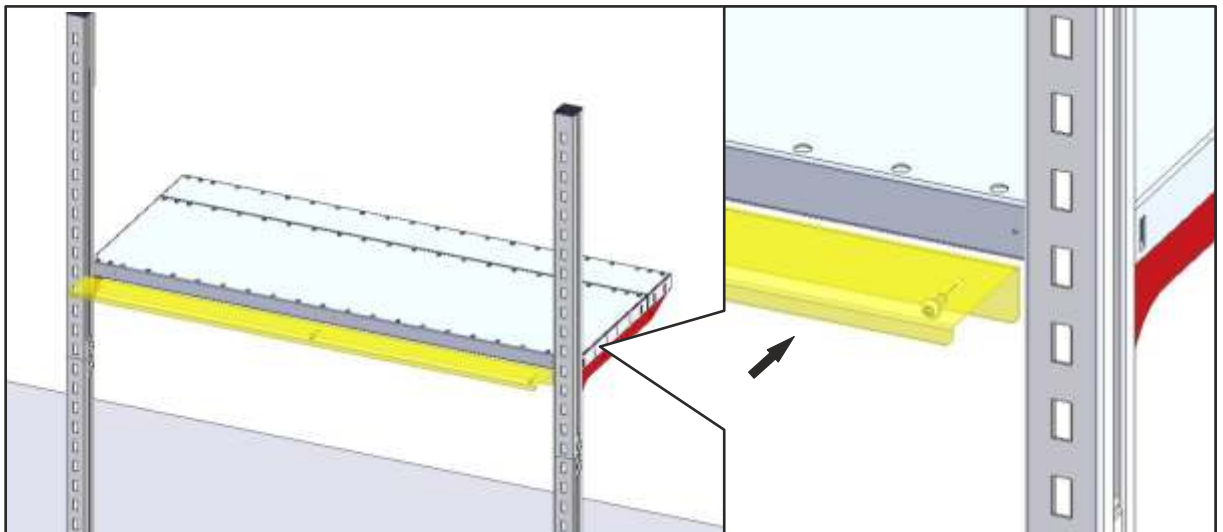

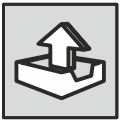

Lieferumfang  
Contents  
Contenu  
Contenido



Montageanleitung  
Mounting instructions  
Instructions de montage  
Instrucciones de montaje



Gebrauchsanleitung  
Instructions for use  
Mode d'emploi  
Modo de empleo

73312700, 73312800

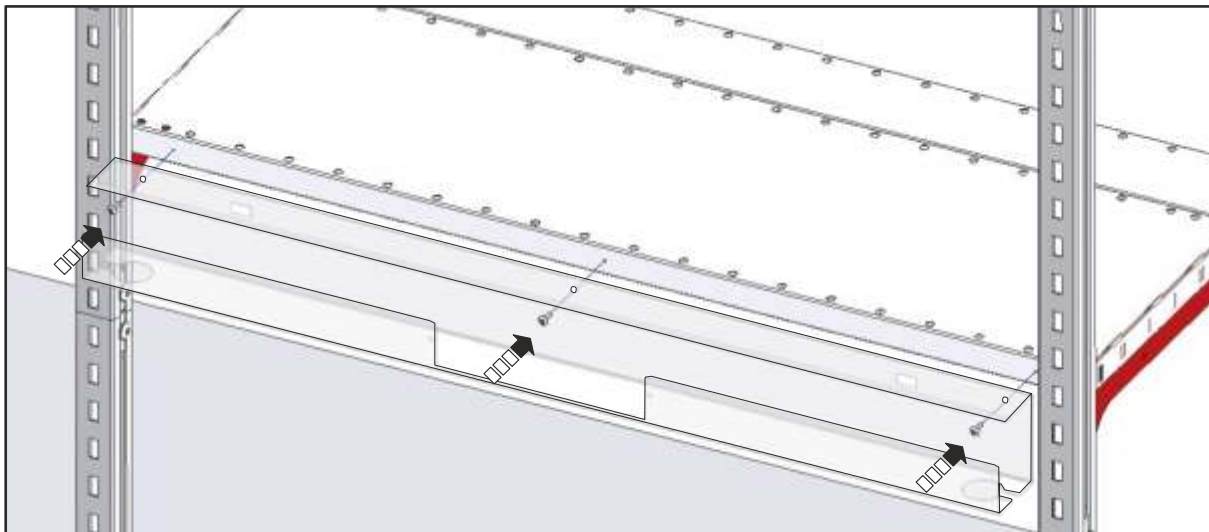
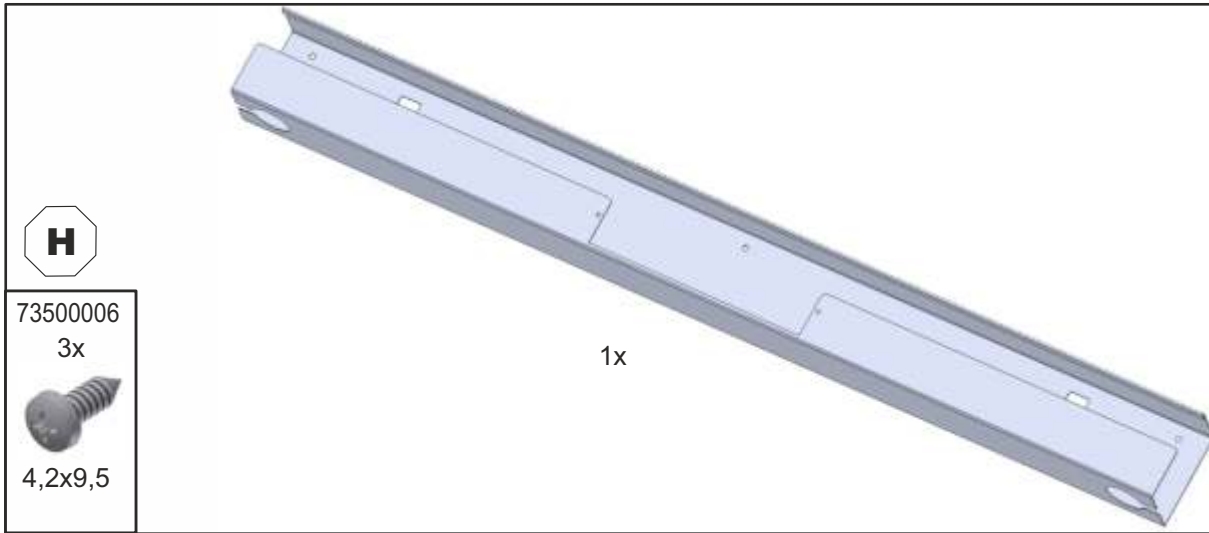
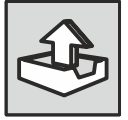

H

Optionales Zubehör / Optional accessories / Accessoires optionnels / Accesorios opcionales

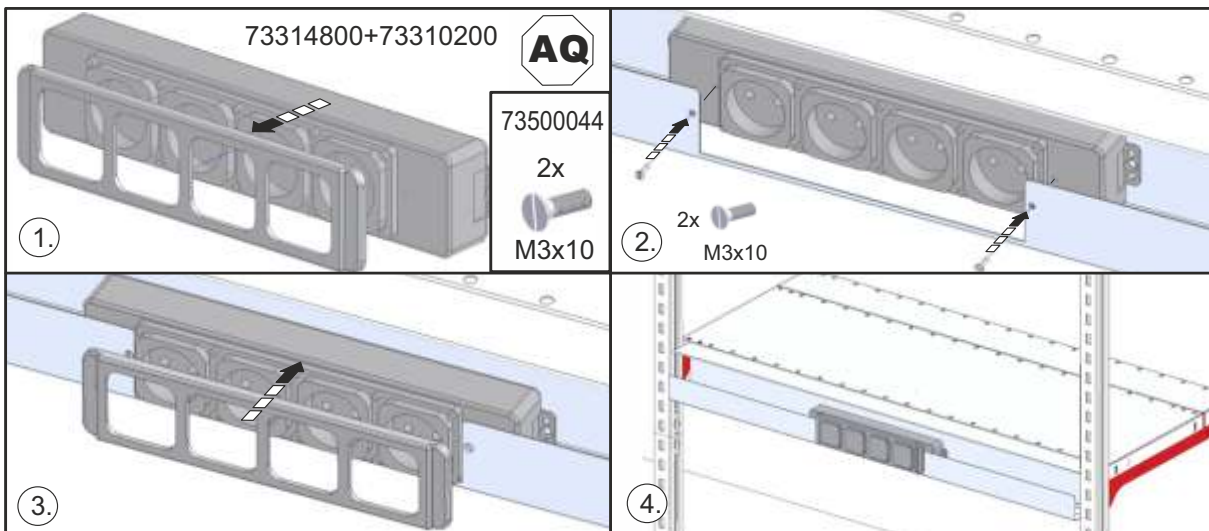

AQ

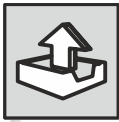

Lieferumfang  
Contents  
Contenu  
Contenido



Montageanleitung  
Mounting instructions  
Instructions de montage  
Instrucciones de montaje



2 Personen  
2 Persons  
2 Persones  
2 Personas

73600015, 73600040

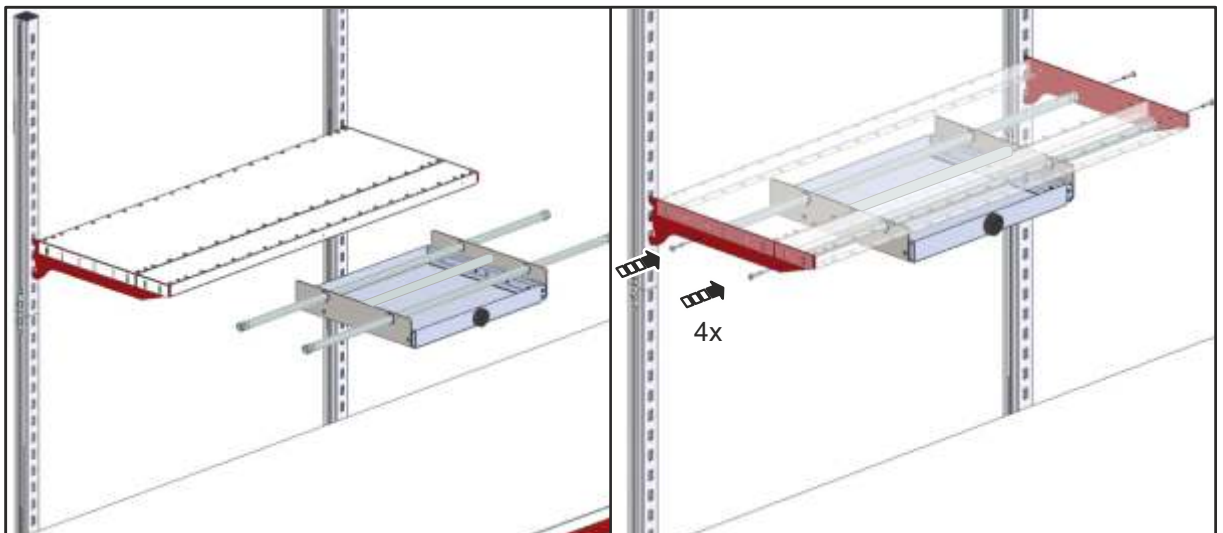
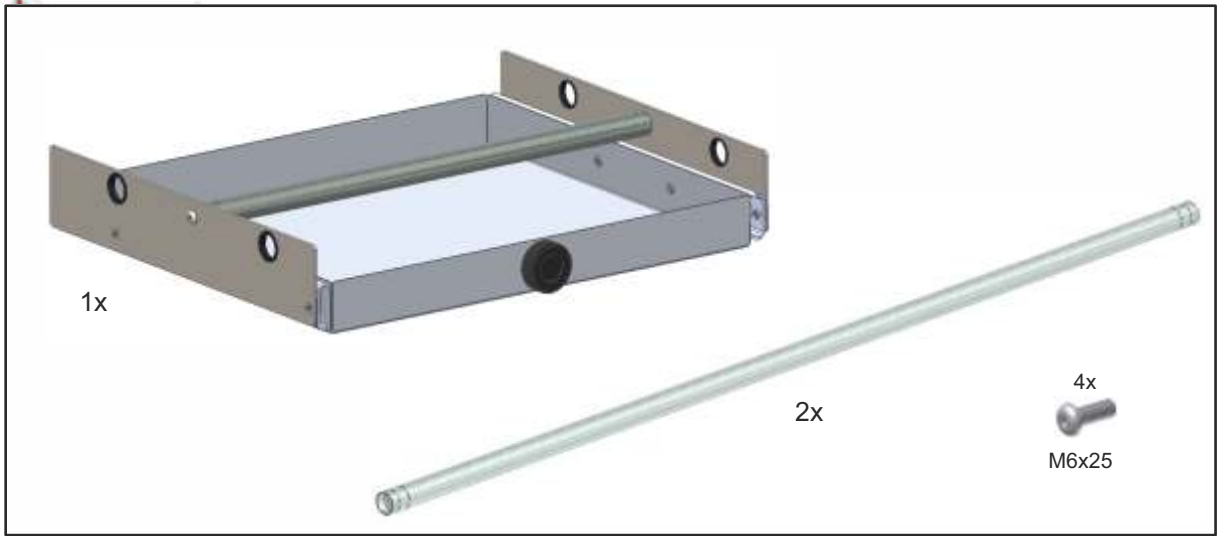
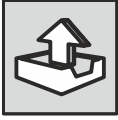

73311600, 73311601

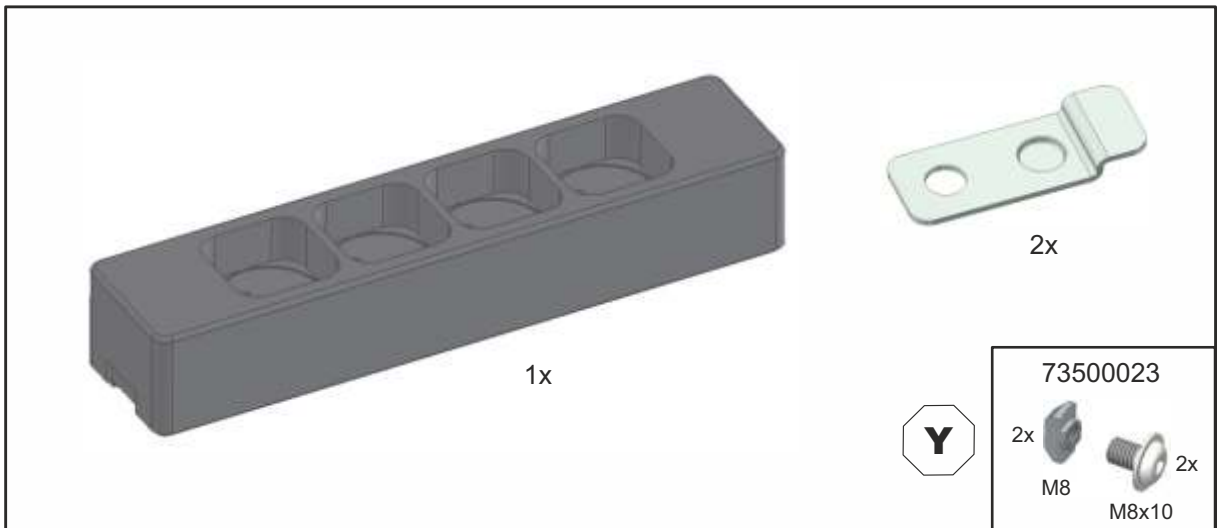
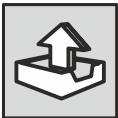





Lieferumfang  
Contents  
Contenu  
Contenido



Montageanleitung  
Mounting instructions  
Instructions de montage  
Instrucciones de montaje



Gebrauchsanleitung  
Instructions for use  
Mode d'emploi  
Modo de empleo

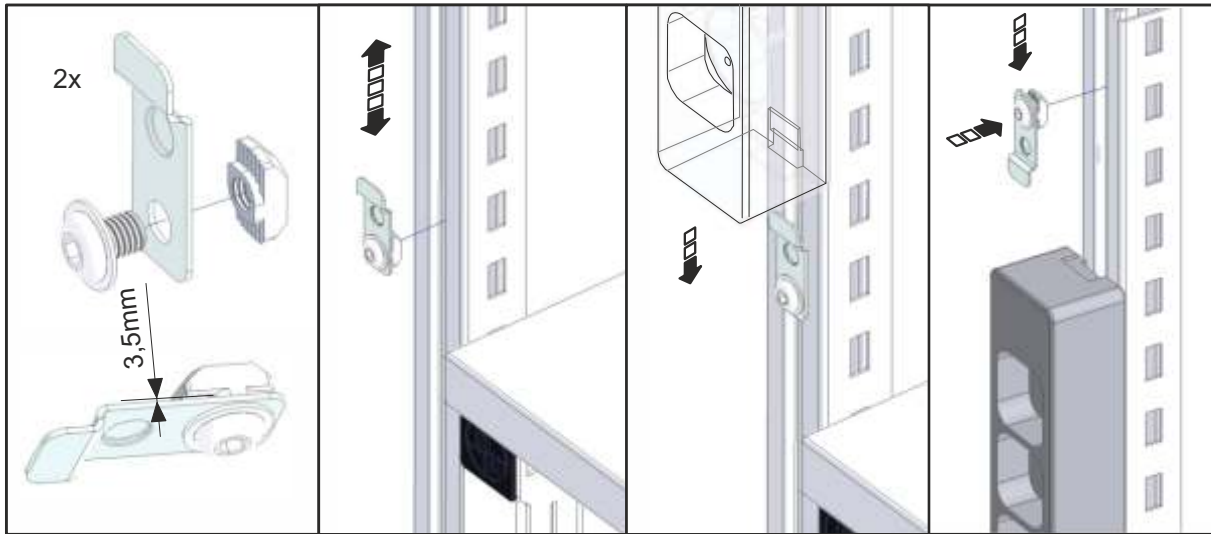

Y

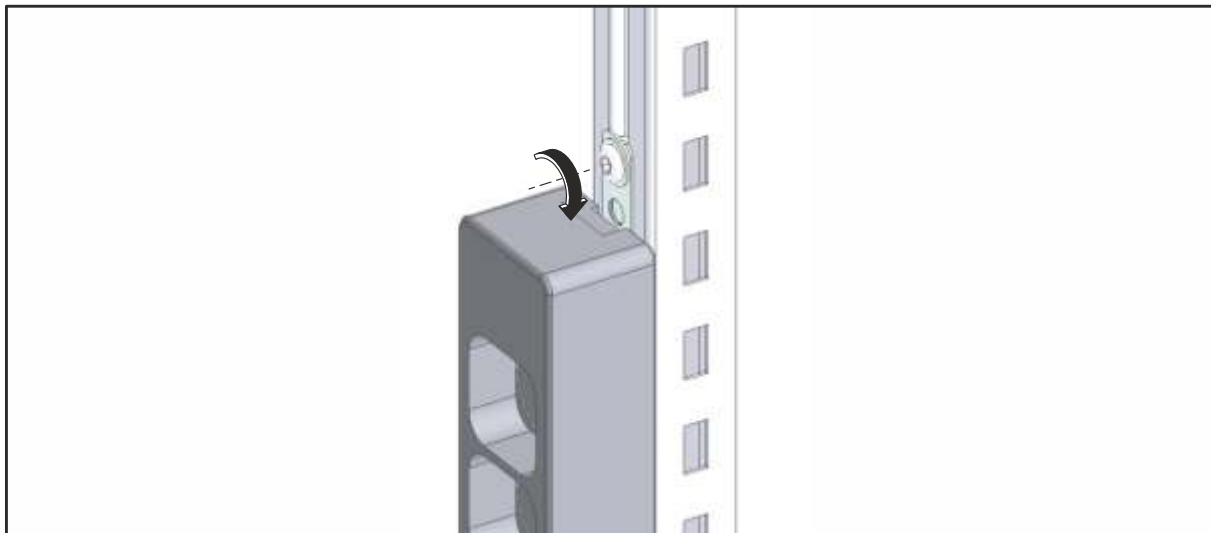

73600086, 73600253

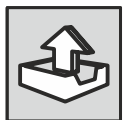
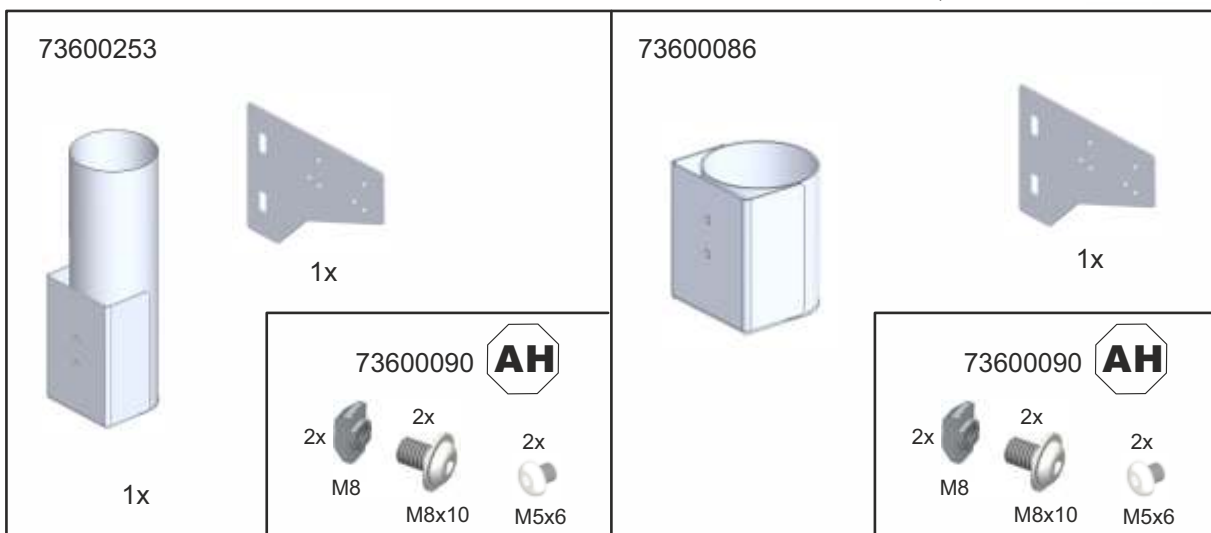

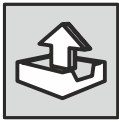

Lieferumfang  
Contents  
Contenu  
Contenido



Montageanleitung  
Mounting instructions  
Instructions de montage  
Instrucciones de montaje



Gebrauchsanleitung  
Instructions for use  
Mode d'emploi  
Modo de empleo



AH

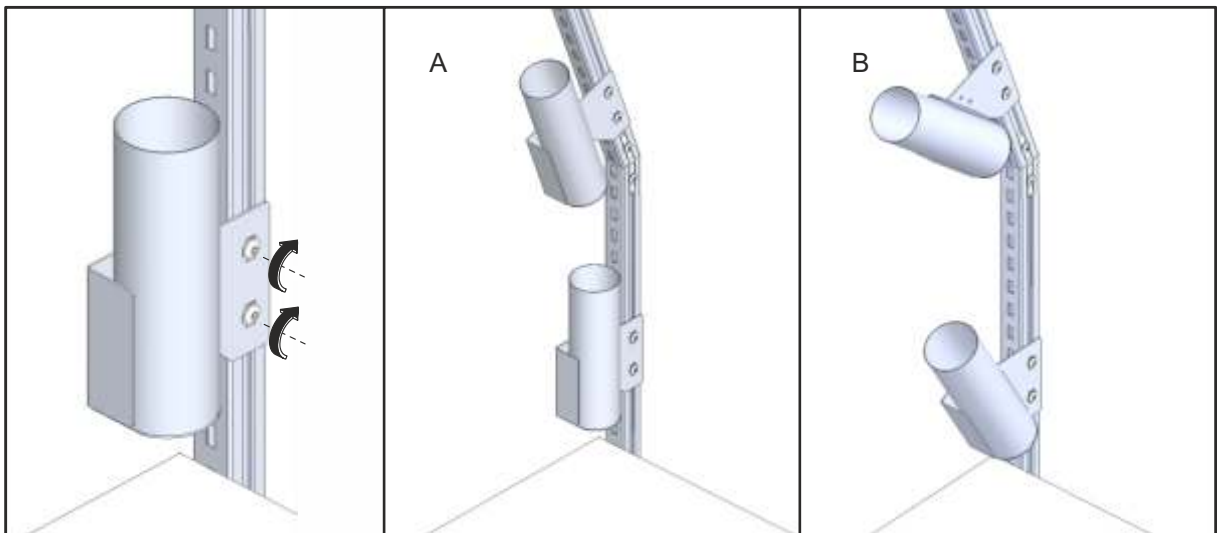
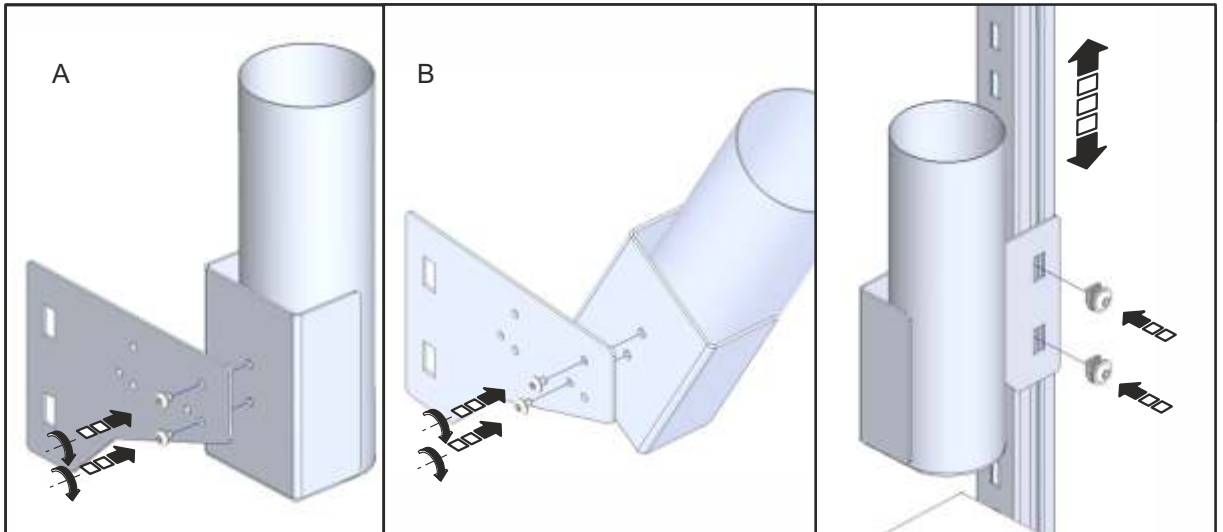

73313600

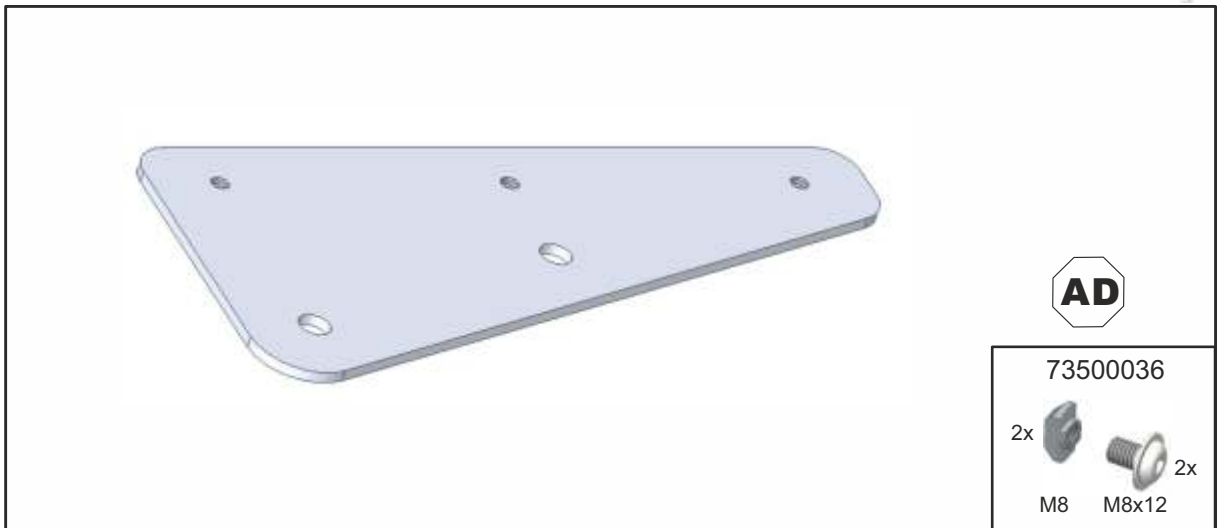
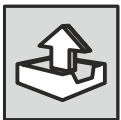



Lieferumfang  
Contents  
Contenu  
Contenido



Montageanleitung  
Mounting instructions  
Instructions de montage  
Instrucciones de montaje



Gebrauchsanleitung  
Instructions for use  
Mode d'emploi  
Modo de empleo

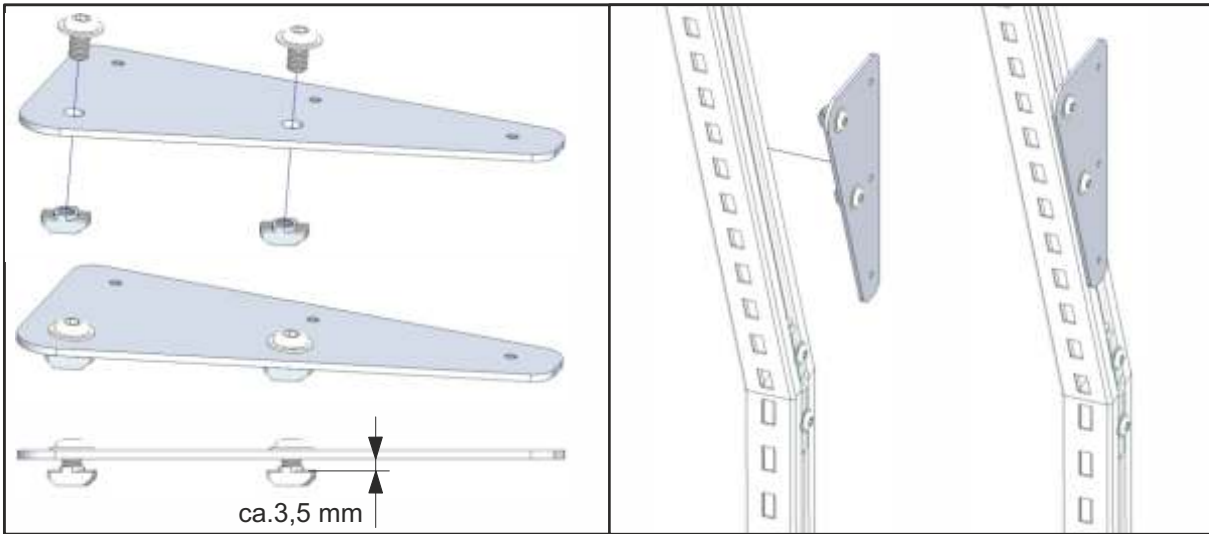

AD

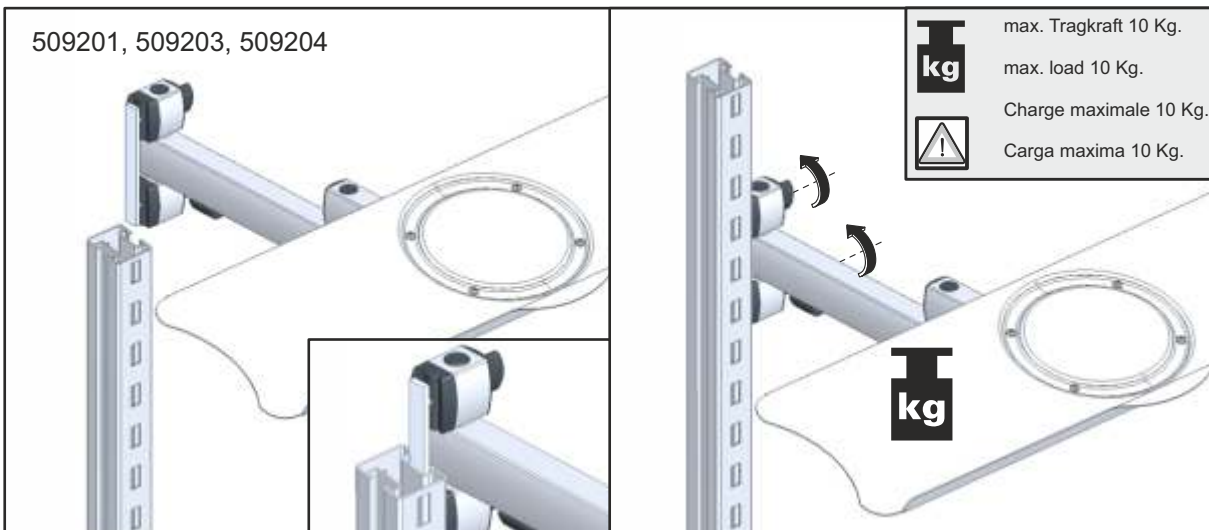
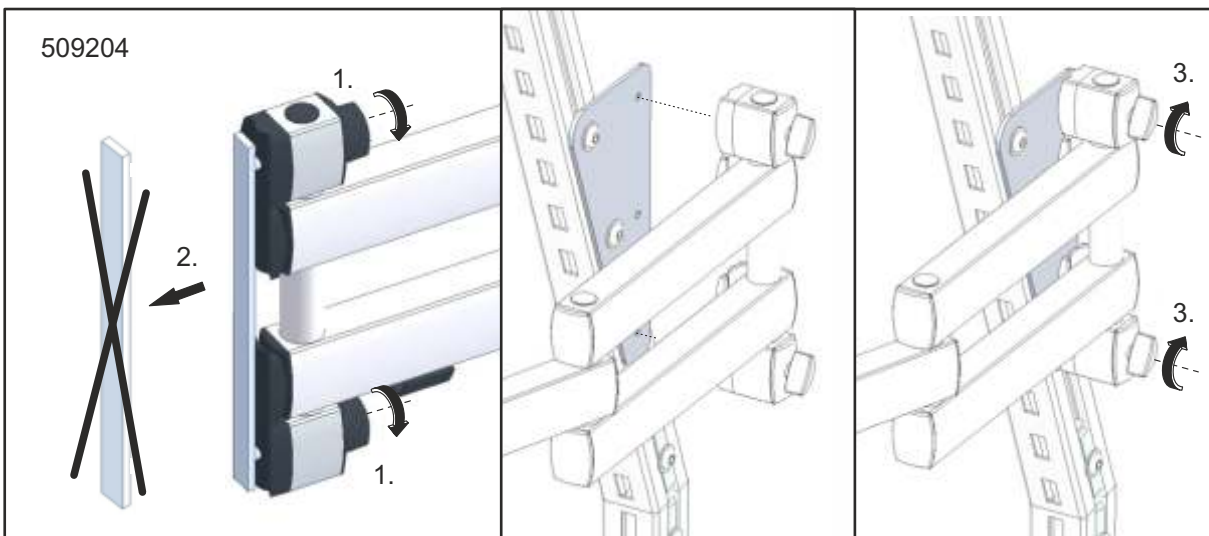

max. Tragkraft 10 Kg.  
max. load 10 Kg.  
Charge maximale 10 Kg.  
Carga maxima 10 Kg.



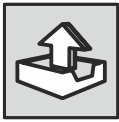

Lieferumfang  
Contents  
Contenu  
Contenido



Montageanleitung  
Mounting instructions  
Instructions de montage  
Instrucciones de montaje



Gebrauchsanleitung  
Instructions for use  
Mode d'emploi  
Modo de empleo

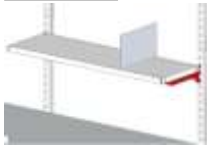

73314700

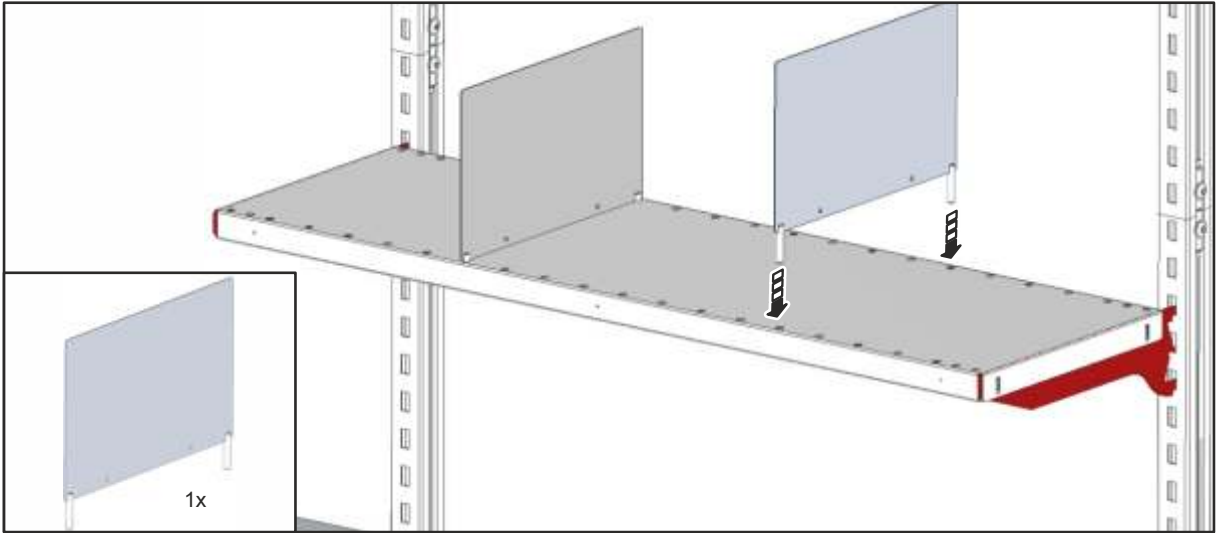
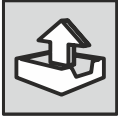

73600504

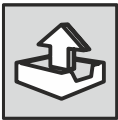

AU

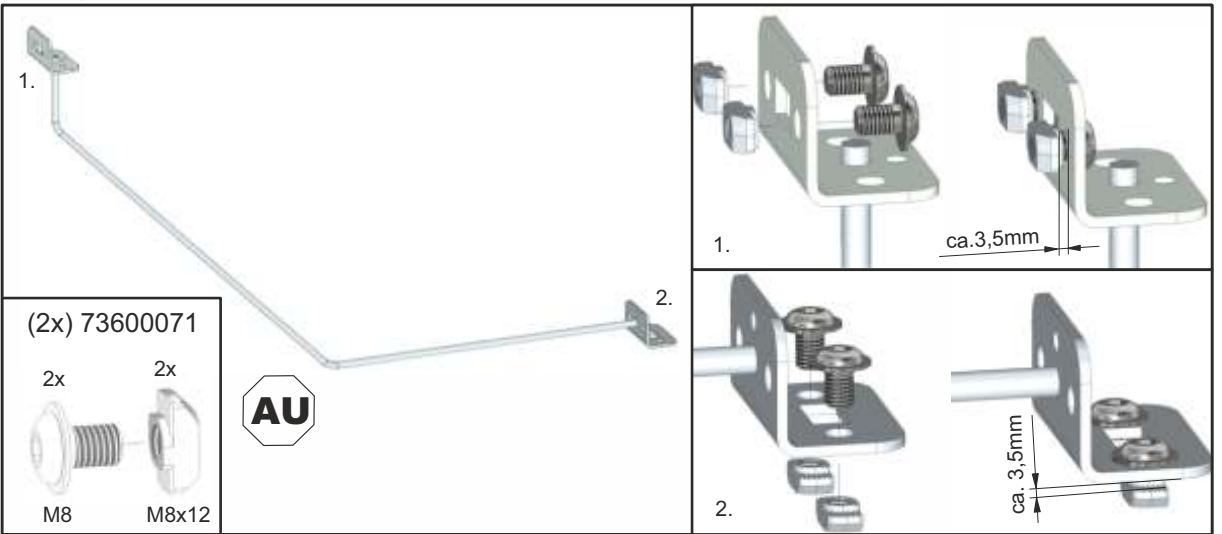

AU

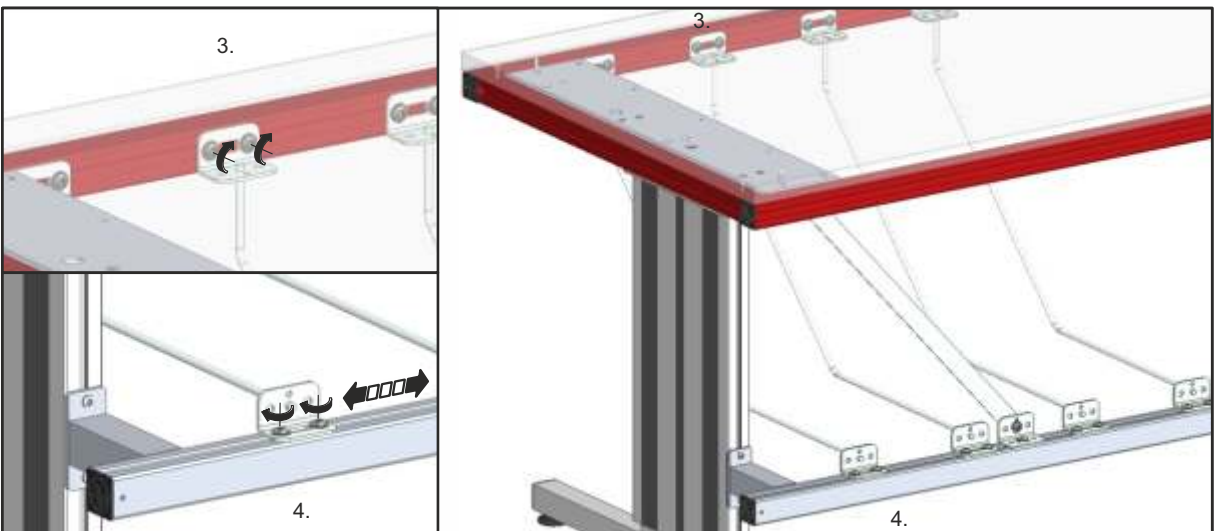



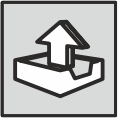

Lieferumfang  
Contents  
Contenu  
Contenido



Montageanleitung  
Mounting instructions  
Instructions de montage  
Instrucciones de montaje



Gebrauchsanleitung  
Instructions for use  
Mode d'emploi  
Modo de empleo

73310700



509314

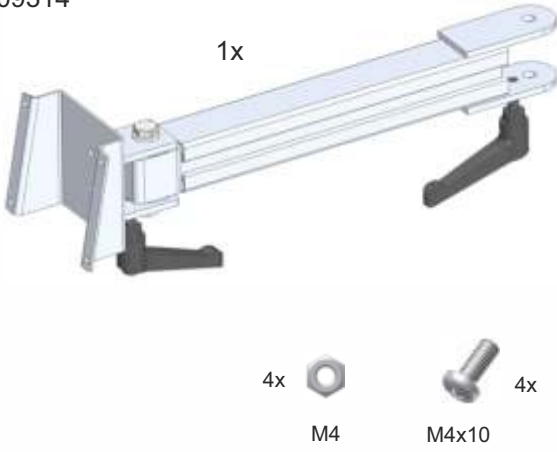

509320

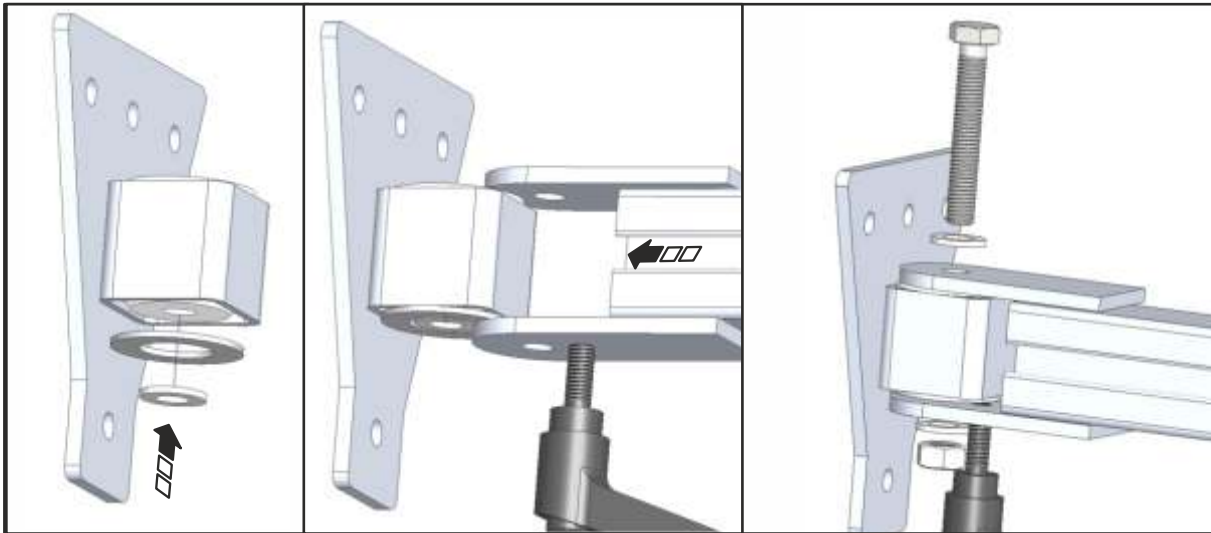
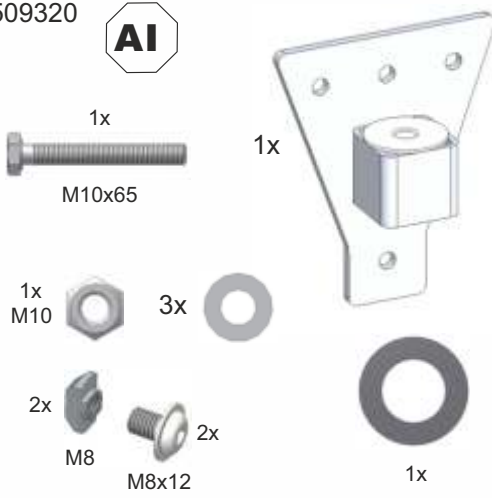

AI

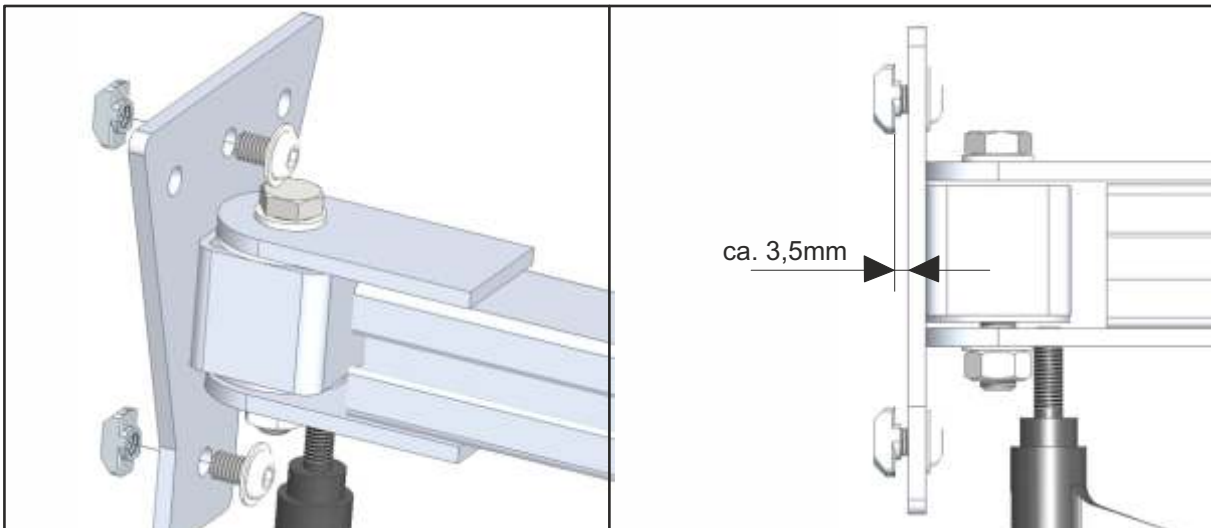

AI

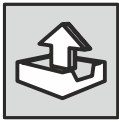

Lieferumfang  
Contents  
Contenu  
Contenido



Montageanleitung  
Mounting instructions  
Instructions de montage  
Instrucciones de montaje



Gebrauchsanleitung  
Instructions for use  
Mode d'emploi  
Modo de empleo

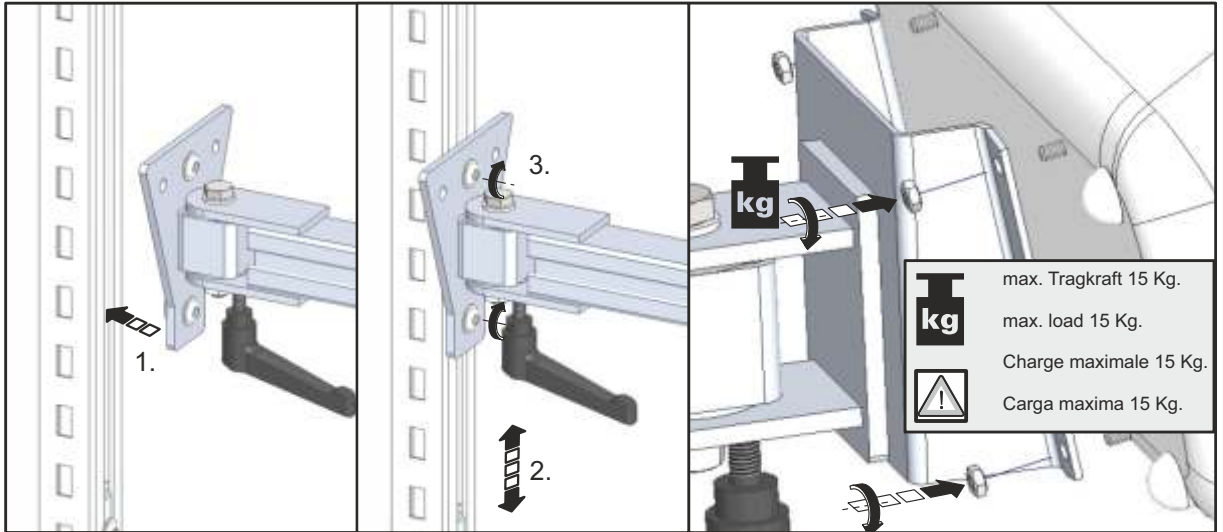

73311100

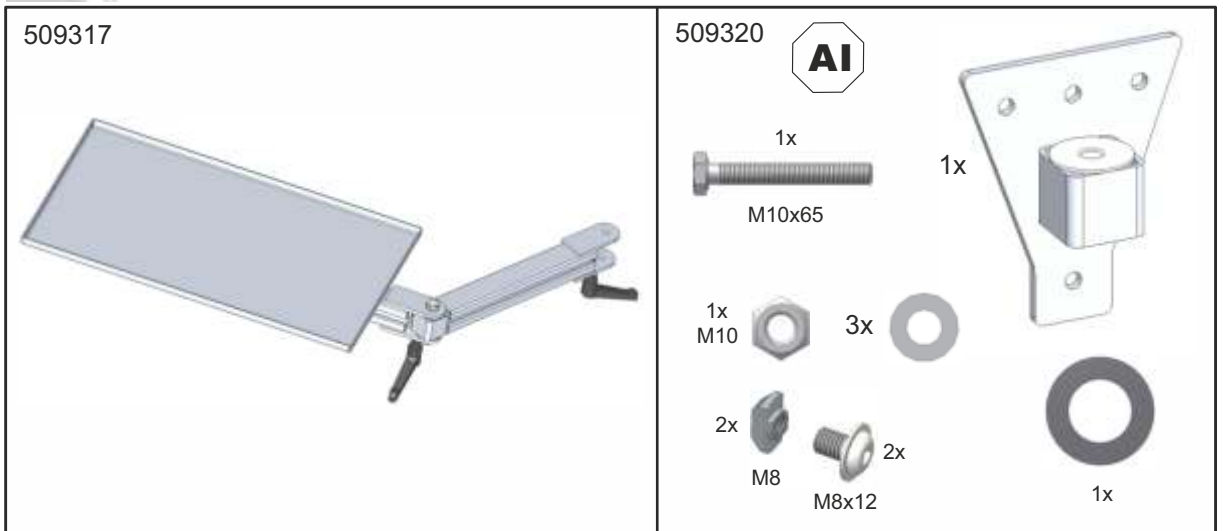
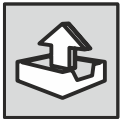

**AI**

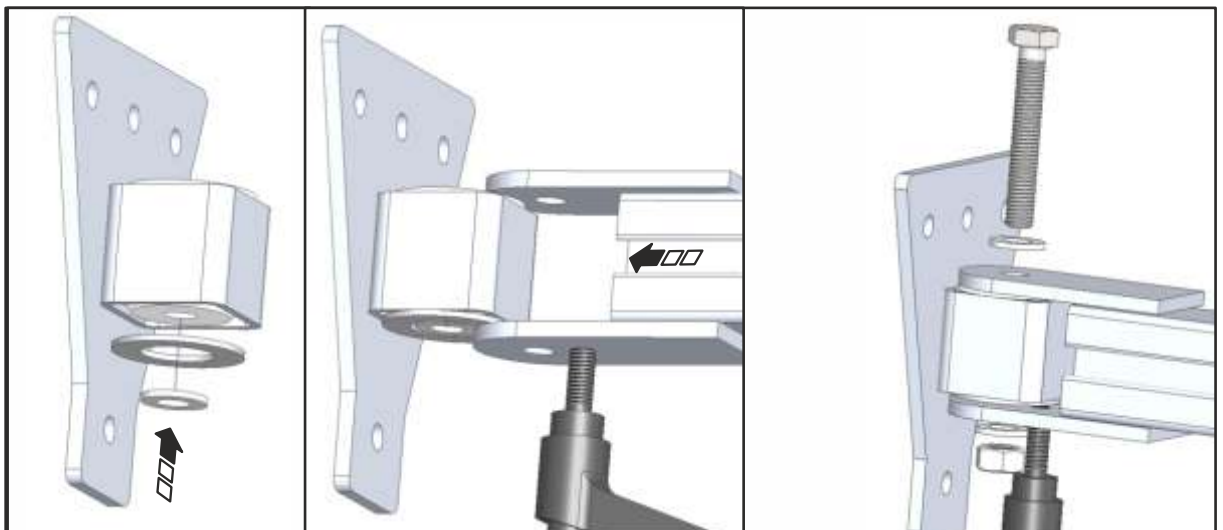

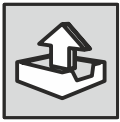

Lieferumfang  
Contents  
Contenu  
Contenido



Montageanleitung  
Mounting instructions  
Instructions de montage  
Instrucciones de montaje



Gebrauchsanleitung  
Instructions for use  
Mode d'emploi  
Modo de empleo

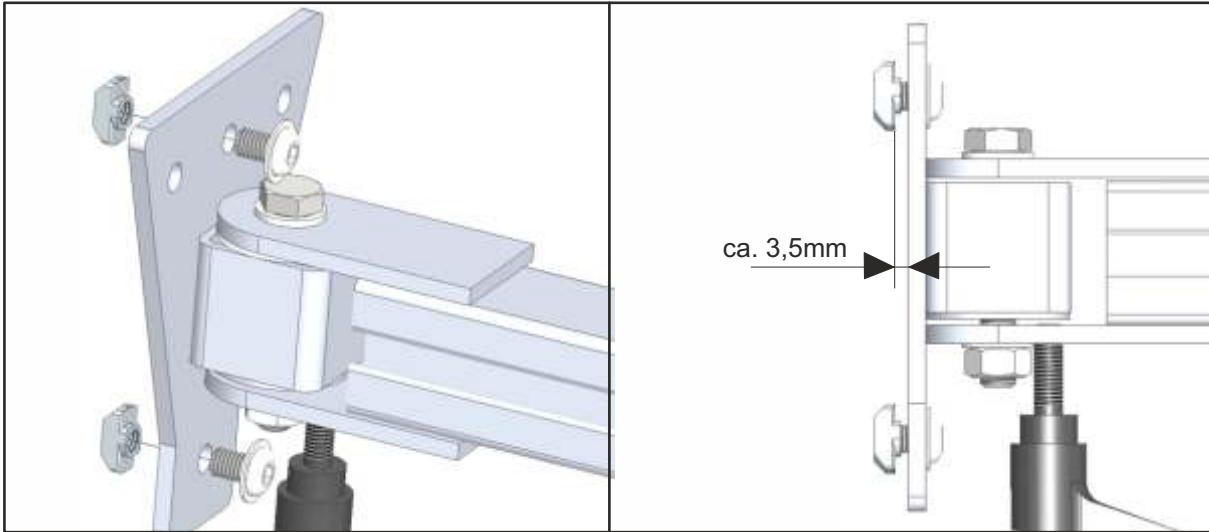

**AI**

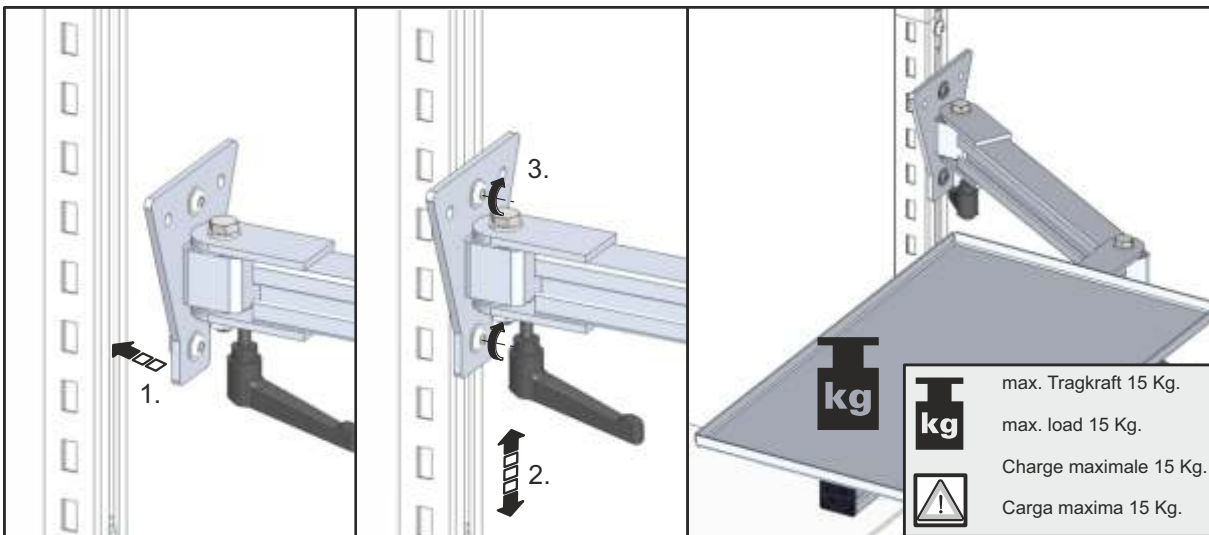

73315000, 73315100

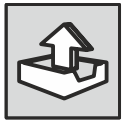
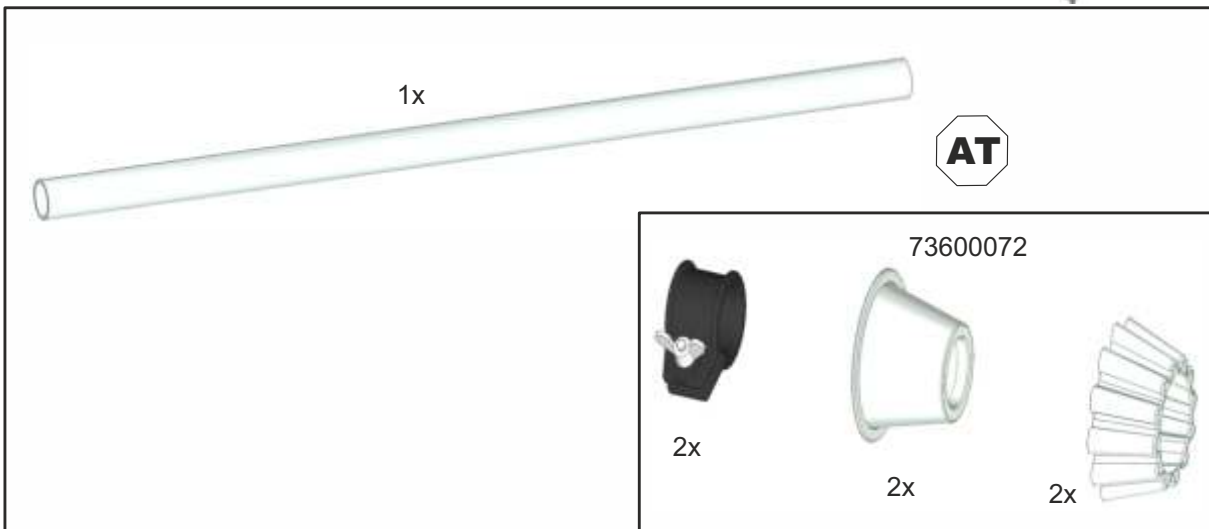

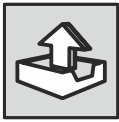

Lieferumfang  
Contents  
Contenu  
Contenido



Montageanleitung  
Mounting instructions  
Instructions de montage  
Instrucciones de montaje



Gebrauchsanleitung  
Instructions for use  
Mode d'emploi  
Modo de empleo



AT

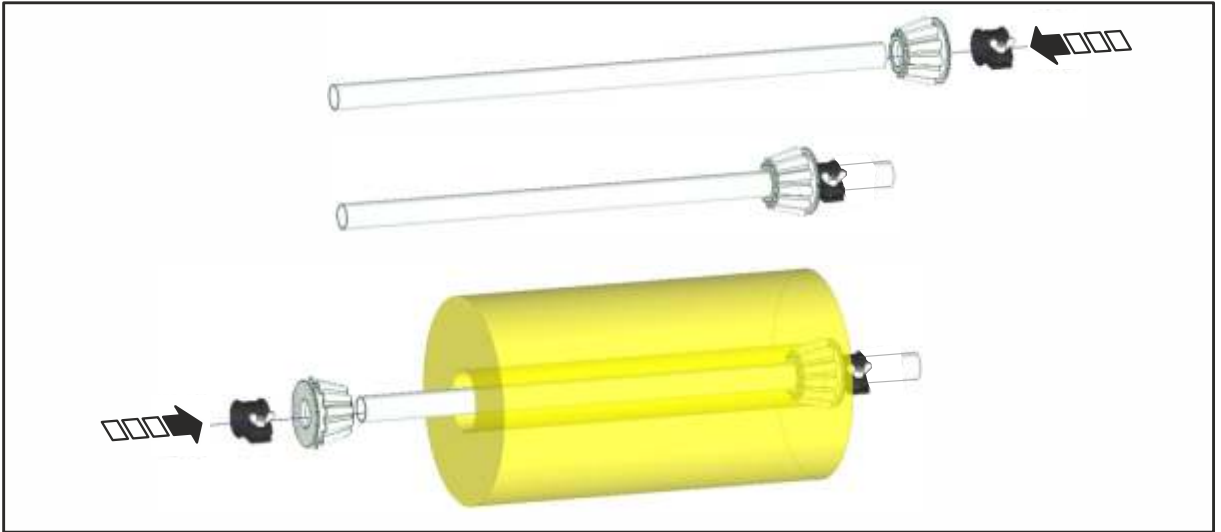

Rolle mittig auf die Achse spannen /  
Please take care to place the roll in the  
center of the rod /  
Mettez la bobine au centre de l'axe

**Abrollrichtung des Materials beachten!**

Pay attention to the direction the materials rolls off!  
Tenir compte du sens de déroulement!  
Observar la dirección del desarrollo del material!



**Rollengewicht max. 25 kg**  
Roll weight max. 25 kg  
Poids max. du rouleau 25 kg  
Peso máx. de rollo 25 kg



73600049

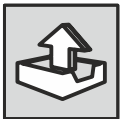

AU

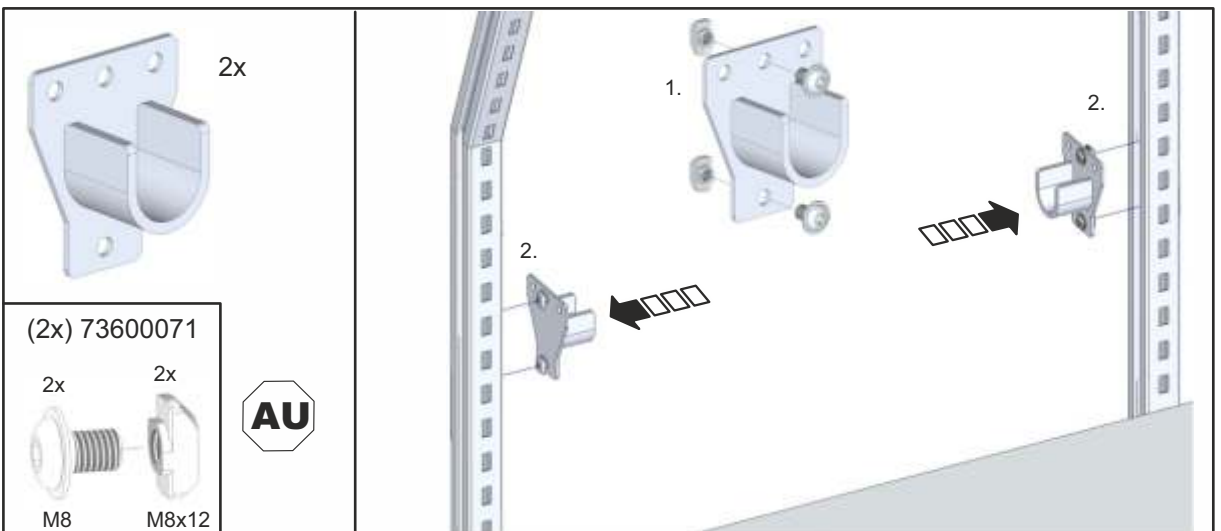

(2x) 73600071

2x

M8

2x

M8x12

AU



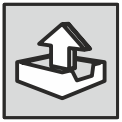

Lieferumfang  
Contents  
Contenu  
Contenido



Montageanleitung  
Mounting instructions  
Instructions de montage  
Instrucciones de montaje



Gebrauchsanleitung  
Instructions for use  
Mode d'emploi  
Modo de empleo

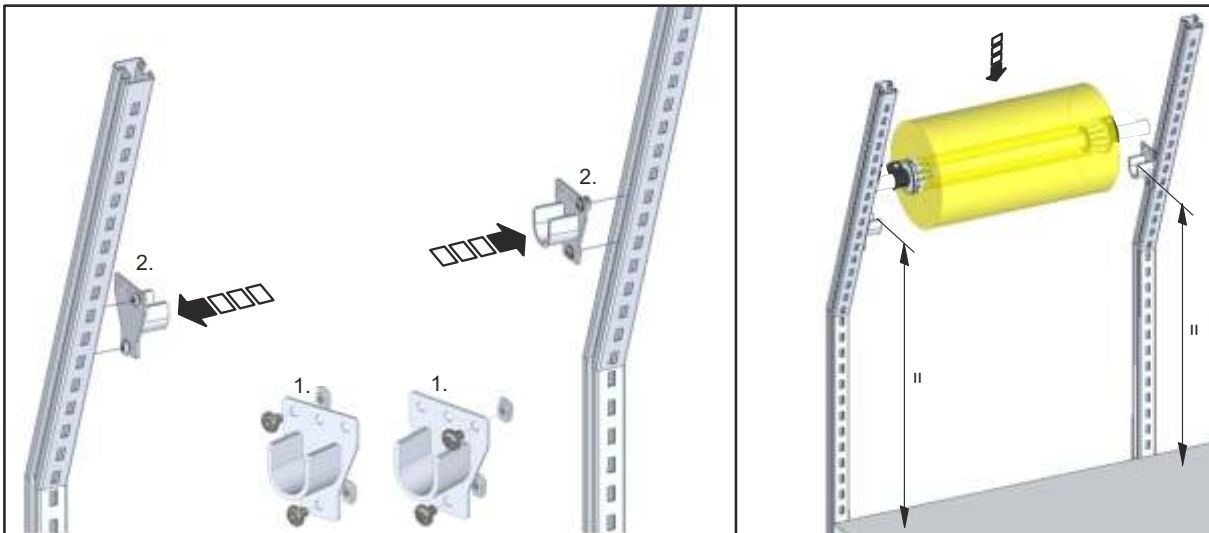
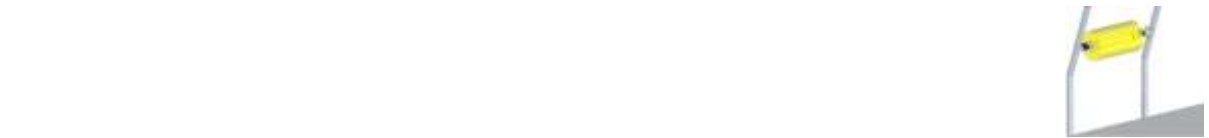
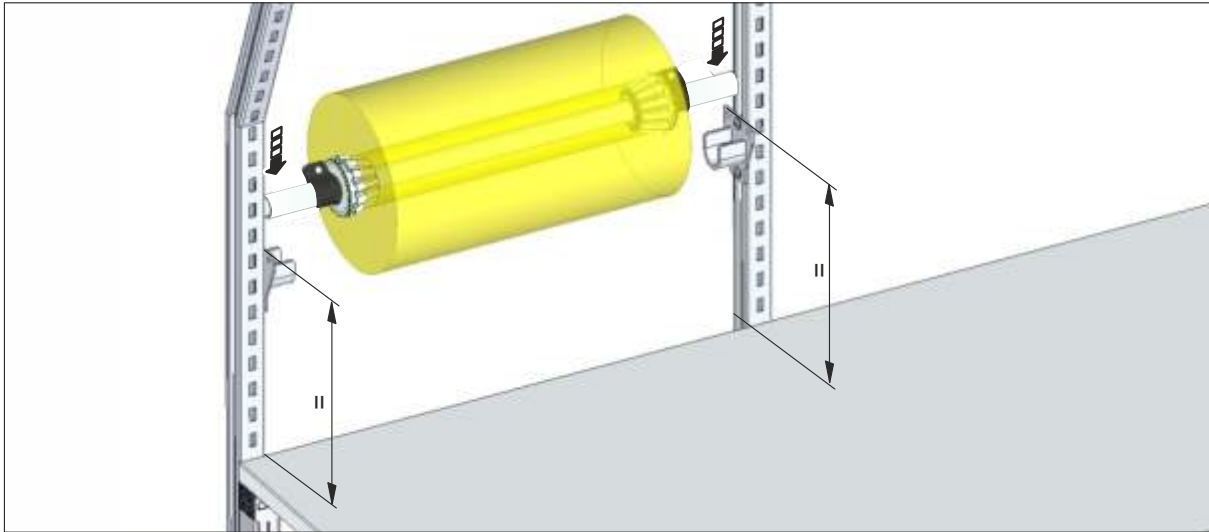

AU

# Gebrauchsinformation

## Information for use

## Information d'emploi

## Información de uso

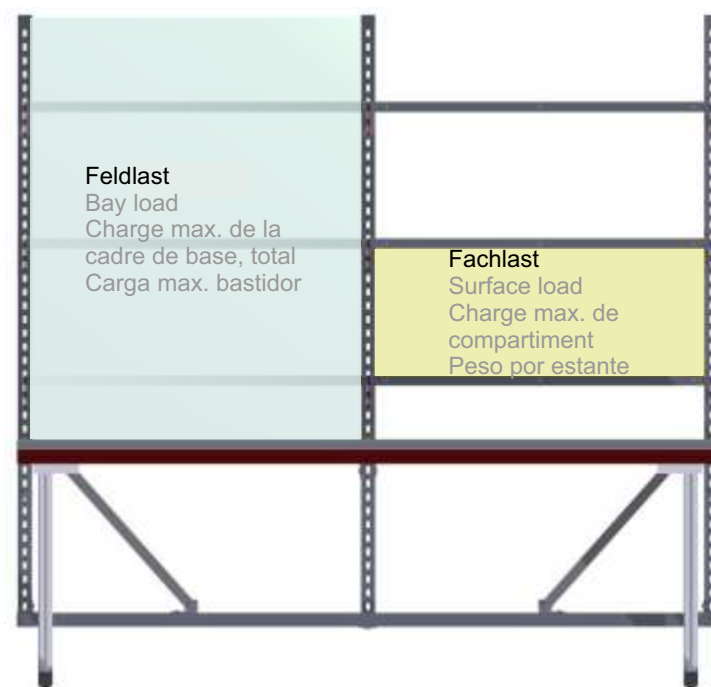

Die Einschaltdauer 2,5 Minuten „ON“ darf nicht überschritten werden. Eine Überschreitung zerstört das System.

Große Punktlasten, sowie stark einseitige Belastungen sind zu vermeiden. Beim Beladen der Anbauten ist darauf zu achten, dass keine großen dynamischen Kräfte entstehen. (z.B. Kartons auf die Ablageböden schmeißen)

Bei den Ablagen ohne gesonderte Angaben zur max. Belastung gilt eine max. zulässige Fachlast von 25 kg.

Grundsätzlich gilt eine max. Feldlast von 60 kg und eine max. Flächenlast auf der Tischplatte von 100 kg.

---

The duty cycle of 2,5 minutes “ON” must not be exceeded. If this duty cycle is exceeded, it destroys the system.

Avoid large point loads and heavy one-sided loads. While loading the extensions, take care that no large dynamic forces are created (e.g. throwing boxes on shelves)

Shelves without separate information have a max. surface load of 25 kg.

In general, a max. bay load of 60 kg and a max. surface load on the table top of 100 kg applies.

---

Le durée d'activation de 2,5 minutes “ON” ne doit pas être dépassé. Le transgression détruit le système.

Évitez les charges ponctuelles importantes et les lourdes charges unilatérales. Pendant le chargement des extensions, veuillez à ce qu'aucune force dynamique importante ne soit créée (par exemple en lançant des boîtes sur les étagères).

Les étagères sans information séparée ont un max. charge de surface de 25 kg.

---

No se debe sobrepasar el tiempo de marcha „ON“ de 2,5 minutos. Un desborde destruye el sistema.

Par Compartiment s'applique un max. charge de 60 kg et un charge de surface sur le dessus de table de 100 kg.

Grandes cargas puntuales y cargas unilaterales son de evitar. Se deben evitar las fuerzas dinámicas al cargar sobre los soportes superiores (por ejemplo evitar de echar/tirar paquetes sobre los estantes)

La carga máxima por estante sin ninguna otra indicación es de 25 kg.

Básicamente la capacidad de carga entre los largueros/extensions es de 60 kg y la máxima carga superficial sobre el tablero de la mesa es de 100 kg..